

**PLANETARY
SYSTEMS
CORPORATION**



2303 Kansas Avenue
Silver Spring, MD 20910
(301) 495-0737
info@planetarysys.com

© PSC

2000781L MkII MLB Operating Procedure

Only personnel directly trained and approved by PSC via 3000224 MLB Training Record are authorized to operate a Lightband for any purpose.

Organization Name	
MLB Size (XX.XXX-XX)	
MLB Assembly Number & Revision	
MLB Serial Number	
Operation Purpose (electrical verification, final integration, etc.)	
Location	

This procedure does not involve any high-energy liquids, solid fuels, or any material with inherently hazardous physical or chemical properties.

TABLE OF CONTENTS

1. REVISION HISTORY	3
2. ACRONYMS AND ABBREVIATIONS.....	4
3. INTRODUCTION	5
4. WARNINGS.....	11
5. ANOMALY REPORTING	11
6. HANDLING PRECAUTIONS	12
7. LIGHTBAND MECHANICAL ATTACHMENT	15
8. MATING THE LIGHTBAND.....	19
9. STOWING THE LIGHTBAND.....	24
10. SETTING-FOR-FLIGHT THE LIGHTBAND.....	36
11. DEPLOYING THE LIGHTBAND	45
12. REMOVING THE LIGHTBAND FROM ADJOINING STRUCTURES	57
13. HORIZONTAL INTEGRATION (OPTIONAL)	58
14. LIGHTBAND ELECTRICAL SCHEMATICS.....	60
15. RECOMMENDED SUPPORT EQUIPMENT	61
16. SETUP PICTURES.....	62
17. CAUTION - UNINTENDED ELECTRICAL PATHS	63
18. LCT PROCEDURE.....	64

1. Revision History

Rev	Issued	Created	Reviewed	Change Description
-	02Nov06	RW	RH	Initial document
A to J	11May07 to 17Jan19	Varies	Varies	See prior revisions for details.
K	30Oct20	RH	LB	<ol style="list-style-type: none"> 1) Entire document: general formatting and grammatical improvements. 2) Section 2: added DB-9 description 3) Section 3.1: made this a section 4) Table 3-1: updated descriptions, added Mate operation, electrical column and section references 5) Section 3.3: added this section Table 3-3: added flatness and circularity equipment 6) Table 3-4: incorporated previous Preparing to Compress equipment, added PSC equipment 7) Table 3-5: added video camera, increased recommended qty. of several items for test circuits 8) Section 4: added adjoining structure attachment warning 9) Section 5: added support@ contact email 10) Section 6: added Sep Spring and Retaining Cord handling precautions, added permitted flange contact 11) Section 7: added flatness and circularity recording, added reminder for Sep Connector and Switch attachment 12) Section 8: incorporated prior section 12 (Preparing to Compress) 13) Section 8: used to be a part of the Stow section 14) Step 8.1.4: increased measurement locations from 4 to 6 15) Step 8.1.7: this step used to be later in the procedure 16) Sections 9, 10, 11: added several test circuits to account for the various Lightband switch states. Used to be only one test circuit per operation. 17) Sections 9, 10, 11: added step checking DB-9 cleanliness prior to Lightband attachment. 18) Sections 9, 10, 11: added step to remove power and measurement circuit from Lightband after each operation. 19) Step 9.4.4: added rechecking pre-Stow distance 20) Table 9-1: updated allowable values 21) Table 9-2, Table 10-2, Table 11-2: moved to relevant sections, increased OL resistance to match inspection report 22) Table 10-1: increased allowable time 23) Table 11-1: added note 2 permitting temporary switch reactivation 24) Figure 14-1: updated to include intermediate switch states and operation directions 25) Section 17: added unintended electrical warnings. 26) Step 18.2.1: now references User Manual for LCT qty. 27) Section 18.5: added instructions to reverse the mate w/ LCTs
L	4Apr24	ND	AO	<ol style="list-style-type: none"> 1) Section 4: Added Part Marking language

2. Acronyms and Abbreviations

- A (or Amps) – Ampere (SI unit of electric current)
- AR – As required
- Atm – Standard atmospheric pressure (unit of pressure)
- AWG – American wire gauge
- C – Celsius (unit of temperature)
- CG – Center of gravity
- Ch – Channel
- CMM – Coordinate measuring machine
- DB-9 – Common name for a specific electrical connector (used interchangeably with official size DE-9)
- div – Division (scale on oscilloscope)
- Doc – Document (referring to a PSC internal document number)
- DOF – Degrees of freedom
- DMM – Digital multimeter
- ESD – Electrostatic discharge
- FLH – Flathead (type of screw head, conical shape)
- I – Current (measured in Amps)
- IAW – In accordance with
- in – Inch (unit of length)
- lb – Pound force (unit of force)
- LCT – Lightband Compression Tool
- LV – Launch vehicle
- MBA – Motor Bracket Assembly (a subassembly of the MLB)
- Mk II – Mark II, a model designation of the Motorized Lightband
- MLB – Motorized Lightband (used interchangeably with Lightband)
- mtr – Motor
- NC – Normally closed (the switch terminal that permits current flow when the switch is in its free state/not activated)
- NO – Normally open (the switch terminal that permits current flow when the switch is depressed/activated)
- NTP – Normal temperature and pressure (20°C and 1 Atm)
- OD – Outer diameter
- Ohm (Ω) – SI unit of resistance
- PS – Power supply or power source
- PSC – Planetary Systems Corporation
- QA – Quality assurance
- R – Resistance (measured in Ohms)
- Rev – Revision
- s – Second (SI unit of time)
- SFF – Set-For-Flight, a Lightband specific operation
- SHC – Socket head cap (type of screw head)
- SI – International System of Units
- SN – Serial number
- SV – Space vehicle
- TVAC – Thermal vacuum (an environmental test)
- typ. – Typically
- V – Volt (SI unit of electric voltage)
- V_{DC} – Voltage direct current (measured in volts)
- W – Watt (SI unit of power)

3. Introduction

3.1 Scope

This document describes the steps required to adjoin and operate the MKII Motorized Lightband (MLB). Training and certification by Planetary Systems Corp (PSC), verified via PSC document *3000224 MLB Training Record*, are required to operate any Lightband. The Training Record also specifies the certification's expiration date.

Ensure this is the latest version of the document by visiting PSC's website, <http://www.planetarysystemscorp.com>. If the version trained on was older than that on the website contact PSC to discuss the changes before continuing.

Read this entire document before attempting any procedures. This document shall be completed in order. Steps shall never be skipped unless specifically permitted otherwise.

Contact PSC to clarify any ambiguity or to answer any other questions.

3.2 Lightband Description

The Lightband is comprised of two separable halves. The Lower Ring contains the Hinged Leaves, Retaining Ring, Motor Bracket Assembly (MBA) and Separation Springs. The Upper Ring, smaller and lighter, contains both the Leaf engagement grooves and the spring plungers that help the Leaves disengage from the accepting groove. Typically, the Lower Ring is attached to the launch vehicle (LV) and the Upper Ring is attached to the space vehicle (SV). The electrical interface to operate the Lightband is a DB-9 socket connector on the outside of the MBA. See Figure 3-1 to Figure 3-6. For more information on the Lightband see PSC document *2000785 MkII MLB User Manual*.

The Lightband is not ESD-sensitive.

There are four Lightband operations that shall always be performed in order. The Lightband shall always be attached to adjoining structures per section 7 prior to performing any of these operations.

Table 3-1: Lightband operations

Operation	Description	Requires electrical power to the motors?	Applicable Section
Mate	Placing the Upper Ring on the Lower Ring and then compressing the Separation Springs.	No	8
Stow	The electric motors drive components in the Lightband that mechanically lock together the Lower Ring and Upper Ring.	Yes	9
Set-For-Flight	The electric motors move internal components of the Motor Bracket Assembly at low voltage to minimize separation time and standard deviation. This also verifies motor torque margin prior to Deploying.	Yes	10
Deploy (separate)	The electric motors drive components that mechanically release the Lower and Upper Rings. In flight, the Separation Springs will then elongate and impart relative velocity between the two Rings. On the ground, the Springs may not elongate due to compressive weights.	Yes	11

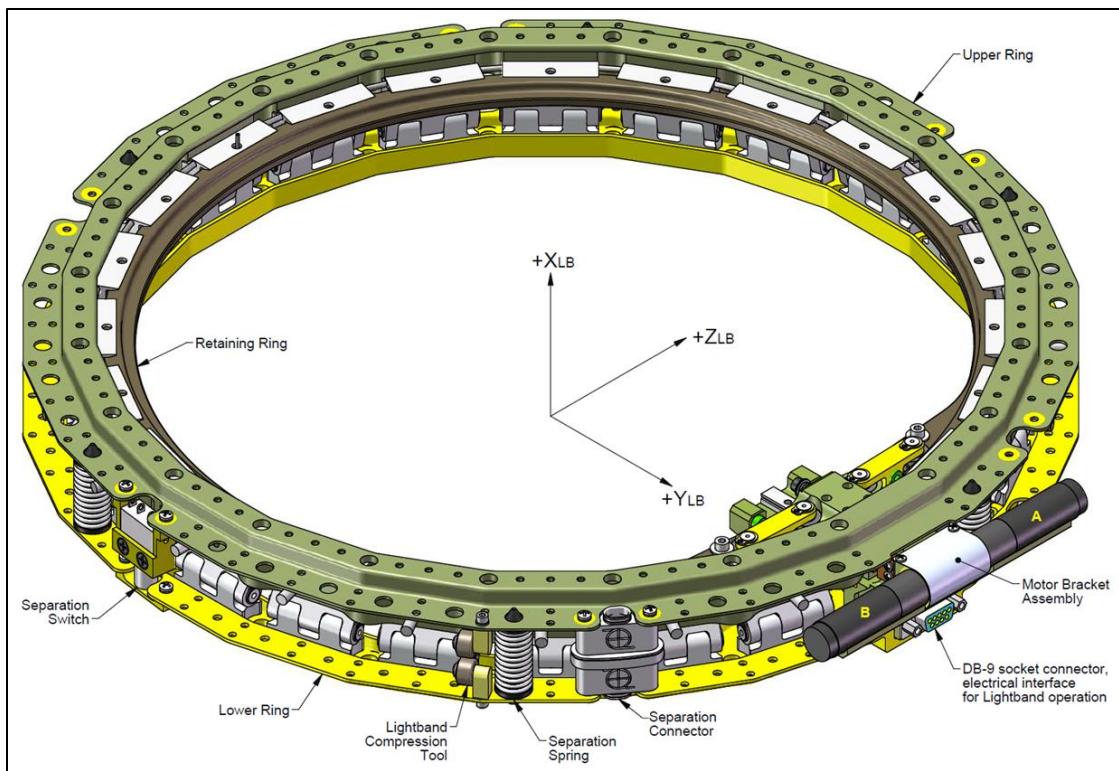

Figure 3-1: MLB15.000-24, Stowed

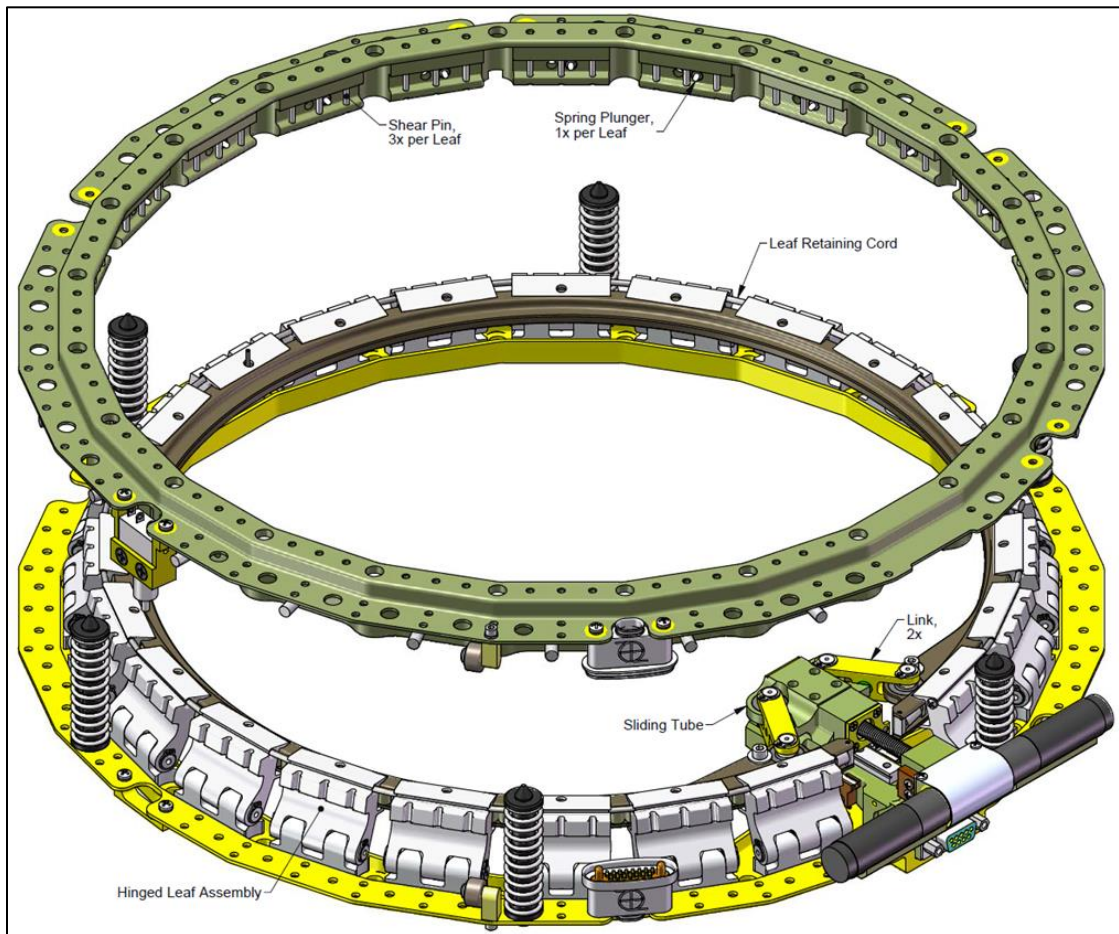

Figure 3-2: MLB15.000-24, Deployed (also referred to as separated)

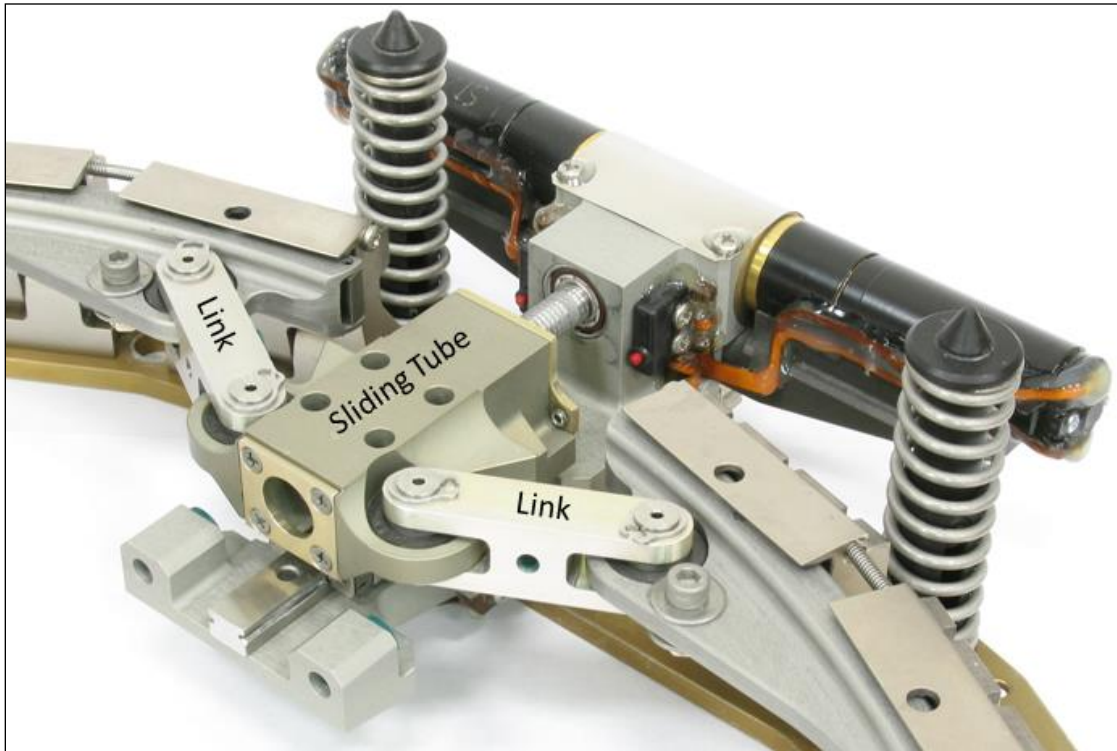

Figure 3-3: Motor Bracket Assembly, internal view

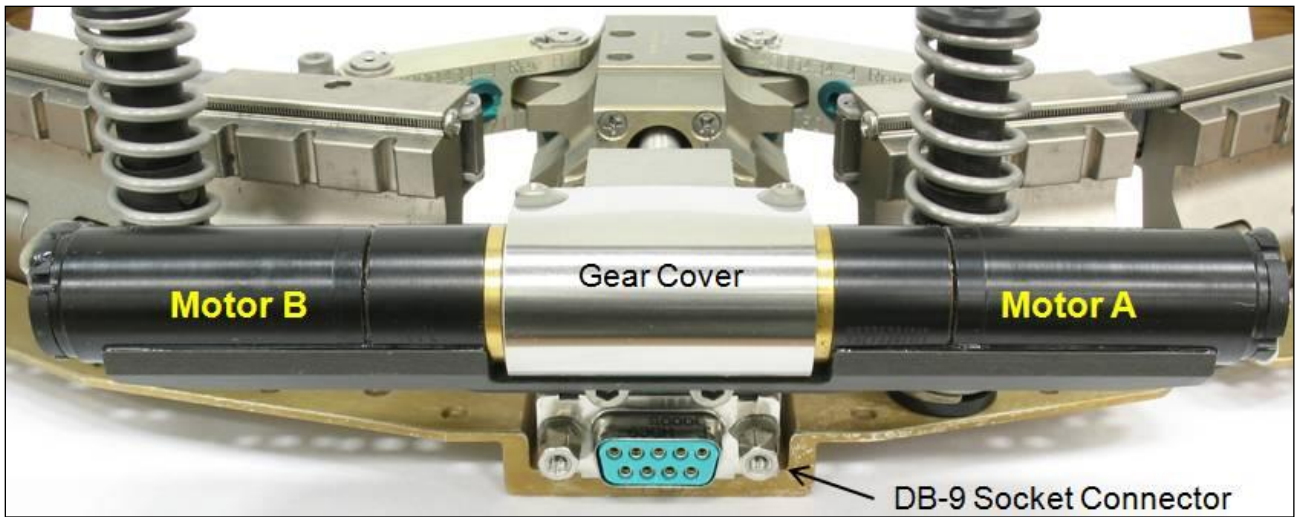

Figure 3-4: Motor Bracket Assembly, external view

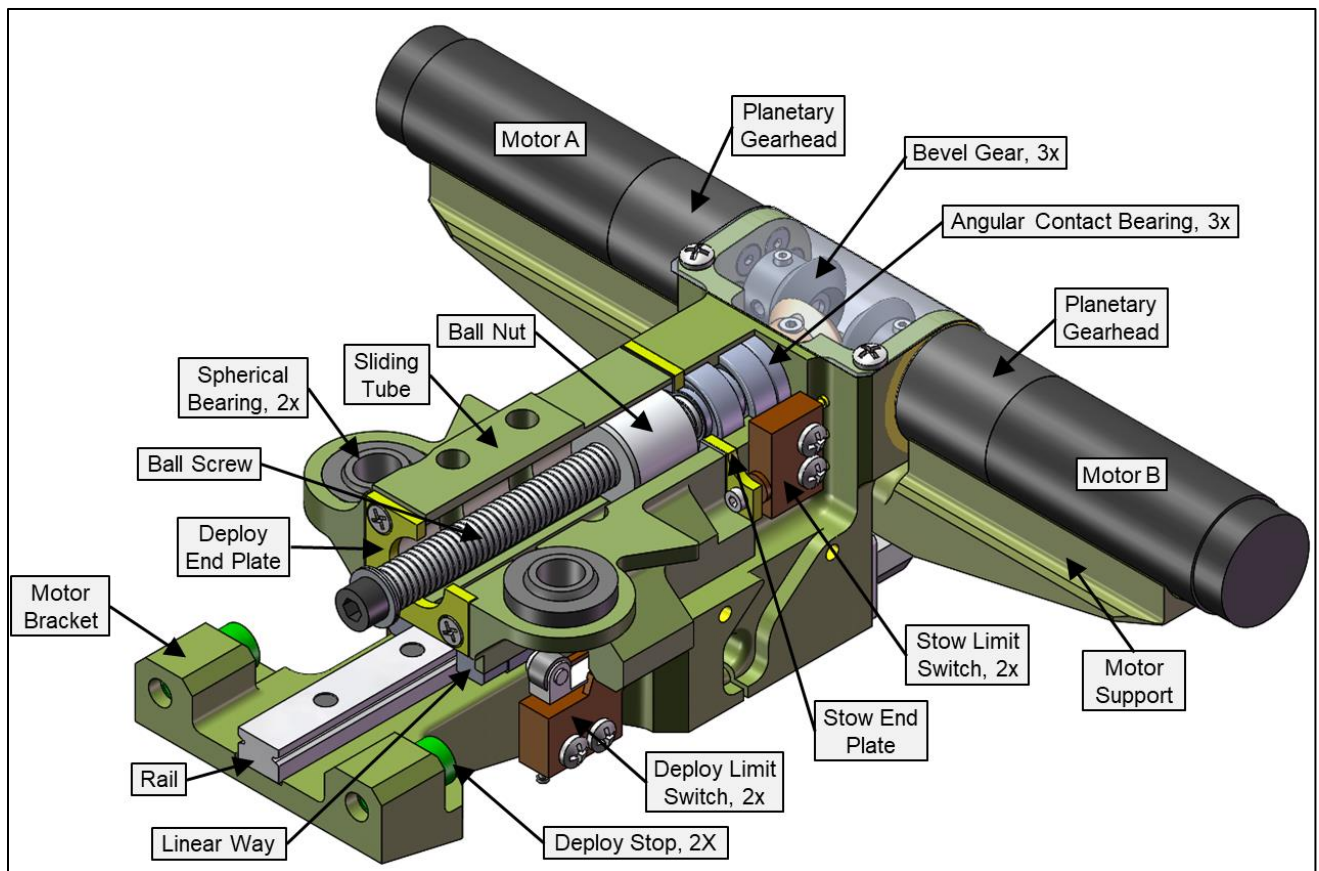

Figure 3-5: Motor Bracket Assembly components, Stowed

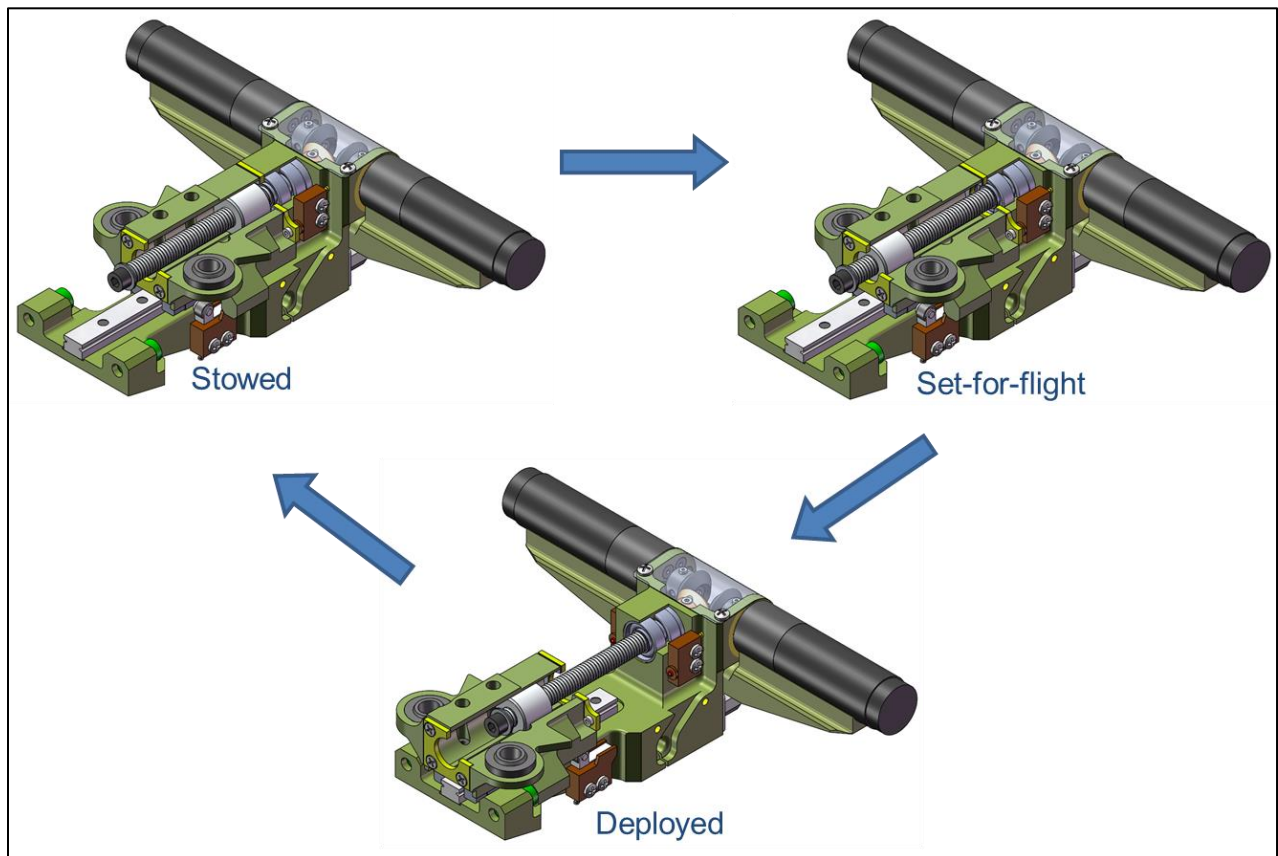

Figure 3-6: Motor Bracket Assembly operations

3.3 Referenced Documents

The following documents are referenced throughout the procedure. Check <http://www.planetarysystemscorp.com> to ensure the latest revision.

Table 3-2: Referenced documents

Document	Necessary For
2000785 MkII MLB User Manual	Adjoining structure flatness, Lightband circularity, LCT qty., detailed Lightband description
3000224 MLB Training Record	Verify approval to operate Lightband(s)
1001015 MLB Warranty	-
3000272 Upper Ring Stop Procedure	If using Stow or Deploy Upper Ring Stops to restrain Lightband
2001025 Separation Connector Data Sheet	Attaching Separation Connectors
2002204 Separation Switch Data Sheet	Attaching Separation Switches

3.4 Required Equipment

The items listed below are proven to properly operate the Lightband as presented in this procedure. PSC strongly recommends using this equipment. All procedure steps listing recommended settings assume the PSC Typically Used equipment. All equipment substitutions shall be thoroughly vetted prior to use with the Lightband. For instance, some customers create a custom data acquisition system, thereby negating the need for an oscilloscope. Further, all electrical paths and Lightband switch states shall be considered. See section 17.

Table 3-3: Mechanical attachment (section 7)

Qty	Item	Make & Model Typically Used by PSC
1	Adjoining structure for Upper Ring	PSC 2000741 Transition Ring
1	Adjoining structure for Lower Ring	PSC 2000741 Transition Ring
AR	0.25 inch SHC fastener (to attach Lower and Upper Rings to adjoining structure)	NAS1351N4-XX or PSC 4000845 <i>Reduced Head SHC Screw</i>
AR	<0.50 inch OD washer (to attach Lower and Upper Rings to adjoining structure)	NAS620C416
AR	0.25 inch nut (if applicable, to attach Lower and Upper Rings to adjoining structure)	NASM21043-4
1	3/16 inch hex key (minimum 1.5 inch shank length) with interface for torque wrench	-
1	Torque wrench, 150 in-lb capability	Sturtevant Richmond CCM-150I
1	Small tweezers to aide in fastener handling	-
AR	Isopropanol (to clean adjoining structure and Lightband interfacing surfaces)	-
AR	Lint Free Wipes (to clean adjoining structure and Lightband interfacing surfaces)	-
AR	Ability to measure flatness of adjoining structures (granite table and thickness gages, CMM, laser, etc.)	Starrett 66 Thickness Gage and granite table
AR	Ability to maintain and measure circularity of Lower and Upper Rings after attachment (custom flat head screws or gage pins along with known precise adjoining structure, caliper that spans MLB, etc.)	PSC 2002753 FLH Alignment Screw and 2000741 Transition Ring

Table 3-4: Mating (section 8)

Qty	Item	Make & Model Typically Used by PSC
AR	Ability to compress Lightband (payload, weights, compression fixture, LCTs). See note 1 below.	-
1	Ability to verify Lightband pre-Stow flange distance. Either a) Telescoping Gauge and Caliper to measure Lightband flange separation (1.3 to 2.1 inch range), or b) Go-no go gauge	Starrett 229C and Mitutoyo 500-175-30 or PSC 2002486 MLB Go No Go Stow Gauge
1	Torque wrench capable of indicating 1 in·lb	Seekonk SL-6 or Capri CP21075S
1	7/64 inch ball hex key to fit on torque wrench (regular hex end and universal joint may be substituted for ball driver)	-

- 1) An in-line load cell is highly recommended if using a crane to raise and lower a payload. This allows real-time monitoring of the Lightband's net Separation Spring force.

Table 3-5: Operating (sections 9, 10, 11)

Qty (2)	Item	Make & Model Typically Used by PSC
1	Power source, adjustable, 32 V _{DC} and 6.5 A capability	BK Precision 1687B
12, 26	Patch cord (to create power and measurement and test circuits, minimum 3.5 A per line, recommend black and red colors)	Pomona, Banana-to-Banana, 18 AWG
1	Oscilloscope, 4 isolated channels	Tektronix TPS2014B
1	Ability to save oscilloscope data and transfer to computer	Compact flash card and reader
2	Current probe for oscilloscope, 0.05 to 4.0 A range	Tektronix A622
1	Adjustable timer relay with trigger, 0.5 to 1.5 s with 0.1 s or finer increments	Macromatic TD-78122
1	Trigger switch (minimum 7 A & 32 V)	-
2, 6	10 Ω power resistor, ≥100 W, used to simulate Lightband motor	Dale HL-100-06Z-10R00-J-J
1	Digital Multimeter (DMM) with leads	Fluke 771V
1	DB-9 pin breakout cable to connect to Lightband	custom made
1, 3	DB-9 socket breakout cable for Test Circuits	custom made
1	Digital camera and video camera to record operation	Mobile phone

- 2) Items with dual numbers are the minimum required quantity followed by the recommended quantity. Having the recommended quantity will save time.

Table 3-6: Using LCTs (section 18)

Qty	Item	Make & Model Typically Used by PSC
1	Caliper and telescoping gage to measure Lightband flange separation (1.3 to 2.1 inch range)	Mitutoyo 500-175-30 & Starrett 229C
AR	4000637 Lightband Compression Tool	-
AR	Nylon cable tie, minimum 50 lb breaking strength, 7 inch long (qty. 1 per LCT pair is required but recommend having extras)	MS3367-1-0 (The '0' specifies the color. Any final number is acceptable.)
1	Cable tie tool with adjustable force	Ty-Rap ERG 50
1	1/4 inch open end wrench	-
1	Dial torque wrench (not break-over), 12 in·lb capability	Precision Instruments DS1F15CHNM
1	3/32 inch hex key attachment for torque wrench	-
1	Wire cutter (to cut cable tie)	-
1	Optional: break-over torque wrench with 3/32 inch hex key, 12 in·lb capability (useful if access to LCTs is limited)	

4. Warnings

Violating any of the below shall void PSC document *1001015 MLB Warranty*.

1. All technicians completing this procedure shall be trained directly by PSC and given authority to operate the Lightband(s) stated in PSC document *3000224 MLB Training Record*.
2. The Lightband shall only be operated using this procedure. This procedure shall be filled out for every operation of the Lightband. Steps shall not be skipped or modified unless they specifically permit otherwise.
3. If a Lightband ever fails to operate correctly, PSC shall be contacted for recommendations and troubleshooting techniques. Subsequent operations shall not be attempted without first understanding the cause of the failure. See section 5 Anomaly Reporting for instructions.
4. The Lightband shall always be attached to adjoining structures per this procedure prior to Stowing.
5. All fasteners shall be used when attaching the Lightband to adjoining structures. Fasteners shall not be omitted from any mounting hole in the Lightband.
6. Never power the Lightband in the Stow direction without the Upper Ring Mated per Section 8. This would cause damage by repeatedly slamming the MBA drivetrain against a hard stop at high speed and force.
7. The tolerance on the pre-Stowed Lightband distance is not the same as the Stowed tolerance. Ensure objects, like wiring harnesses, routed between the Lightband flanges do not inhibit proper operation. Also do not leave stiff objects, like gage blocks, between the flanges during Stow.
8. The Upper Ring shall be physically separated from the Lower Ring after every Deployment. A Stow operation shall not be attempted without first inspecting the Lightband.
9. Both motors shall always be powered when operating the Lightband.
10. The Lightband shall only be Stowed within the temperature range of 10 to 32 °C (50 to 90 °F).
11. PSC sends power to both motors simultaneously (via a single relay) in all operations. The customer may power each motor via separate circuits provided the timing is synchronized within 0.005 s. This applies to power on and power off.
12. Do not attempt to remove or otherwise tamper with any part markings (engravings, stickers, ink, etc.). PSC shall be contacted if there is any visible damage to the part marking.

5. Anomaly Reporting

If an anomaly occurs, contact support@planetarysystemscorp.com with all the below requested data. Providing all data will avoid confusion and expedite PSC's response.

1. Stop immediately and maintain the existing configuration (if safe).
2. Thoroughly document the Lightband's state with pictures and notes. Pictures of the MBA, Hinged Leaves, and Upper Ring internal leaf grooves are often valuable when troubleshooting. Verify the quality and focus of every picture prior to sending.
3. Provide the three prior operation's electrical profiles (if applicable to anomaly) as an Excel file. Ensure all data is properly formatted, titled, graphed and labeled. Sending only the raw oscilloscope .CSV files will significantly increase PSC's response time. Ensure all date labels correspond to the actual event date.
4. Provide a copy of this as-run procedure.
5. Provide any relevant operation details including, but not limited to:
 - a) Adjoining structures. To what is the Lightband bolted?
 - b) To date, how many Lightband operations have been performed?
 - c) Reason for operation. Was it an environmental test, avionics verification, integration, etc.? This informs potential failure modes.
 - d) Are all components accessible? Are there any access restrictions? Is the Lightband in a clean room?

6. Handling Precautions

Lower Ring

1. Do not touch the ball screw. Be especially careful when installing fasteners adjacent the Motor Bracket Assembly. See Figure 6-1.
2. Do not touch the portion of the Hinged Leaves that engage the Upper Ring. Do not wipe off the grease during cleaning. See Figure 6-2.
3. Do not grab the motors or use them to rotate the Lower Ring.
4. Do not allow the motors to contact anything. This is especially crucial when rotating the Lower Ring. See Figure 6-3.
5. Do not touch the gear cover on the Motor Bracket Assembly. See Figure 6-4.
6. Do not grab the Separation Springs or use them to rotate the Lower Ring. See Figure 6-5.
7. Do not touch the Leaf Retaining Cord. This is especially applicable when attaching the Lower Ring to adjoining structures. See Figure 6-6.

Upper Ring

1. Do not touch the Leaf groove. Do not remove grease from the groove when cleaning. See Figure 6-2.
2. Do not touch the spring plungers. Do not allow the spring plungers to contact anything. See Figure 6-7.
3. Do not place the Upper Ring “face down” on a surface if there are Separation Connectors or Separation Switches installed. Doing so could damage or contaminate Connector pins, Switch plungers or the Upper Ring flange. See Figure 6-8

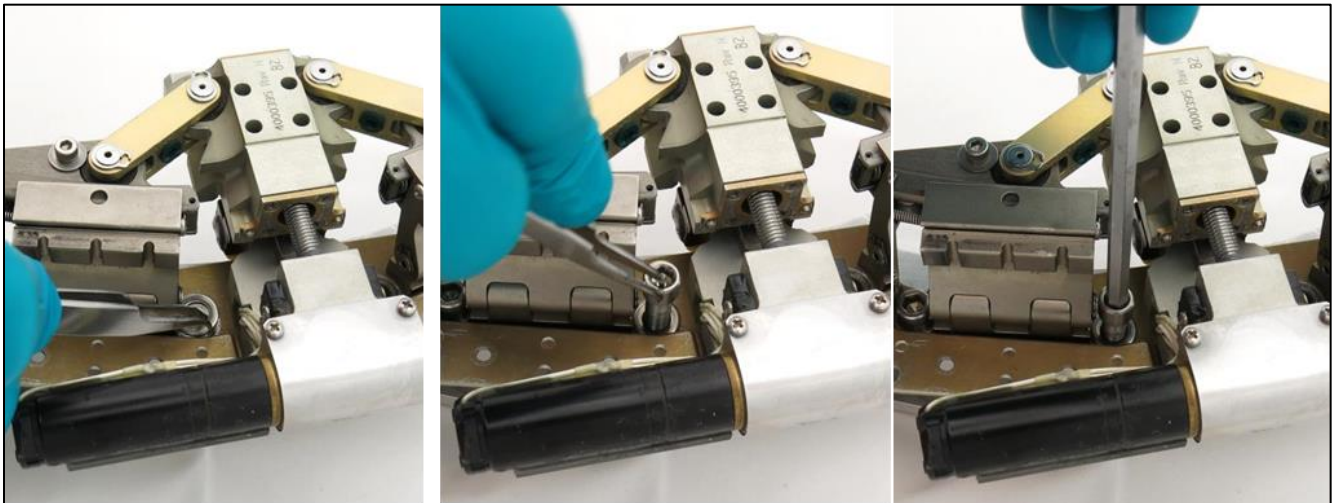

Figure 6-1: Carefully install fasteners immediately adjacent the MBA

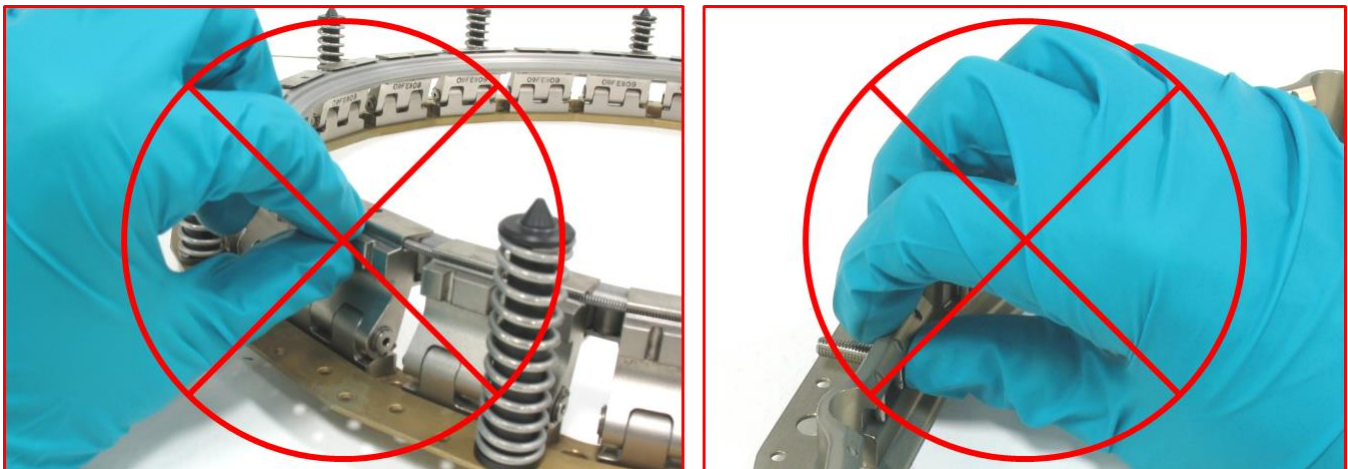

Figure 6-2: Do not touch the Leaf lip or its corresponding groove in the Upper Ring

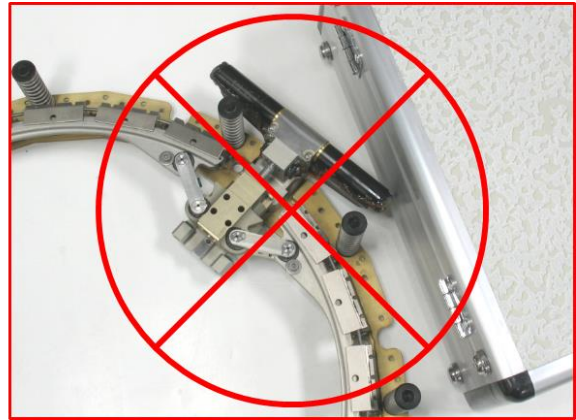
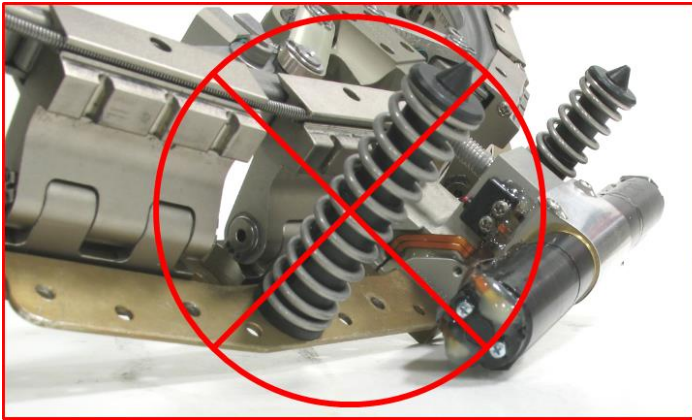

Figure 6-3: Do not allow the motors to contact the table or any other objects



Figure 6-4: Do not touch the gear cover

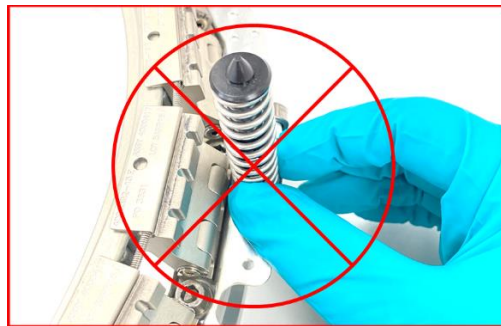

Figure 6-5: Do not touch the Separation Springs

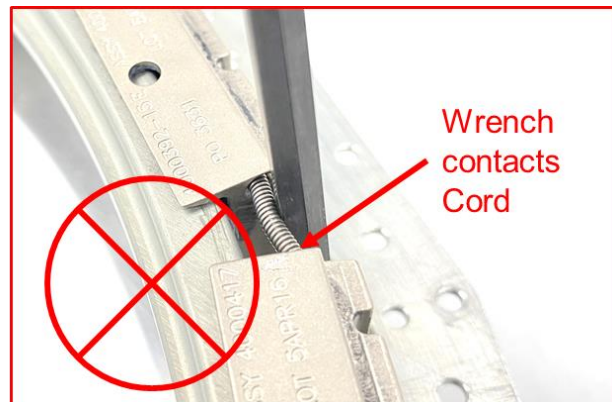
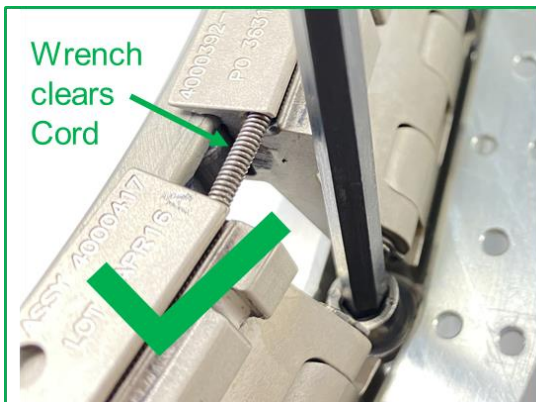

Figure 6-6: Ensure the Leaf Retaining Cord is not contacted



Figure 6-7: Do not touch spring plungers or allow them to contact anything



Figure 6-8: Do not allow Upper Ring accessories to contact anything

Safely handle the Lightband by grabbing the flanges on the Lower Ring and Upper Rings as shown in Figure 6-9.

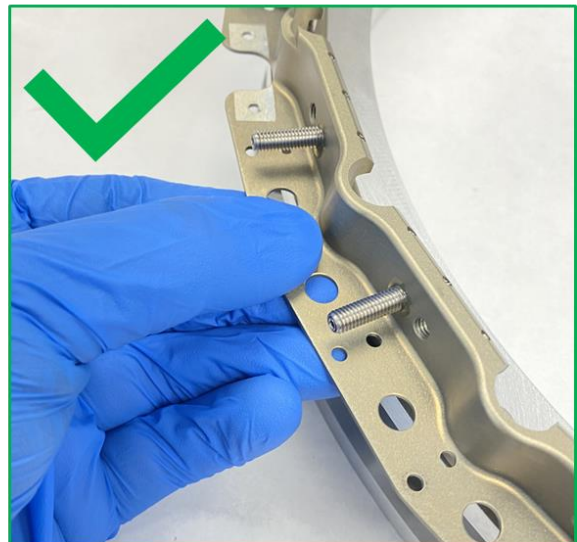
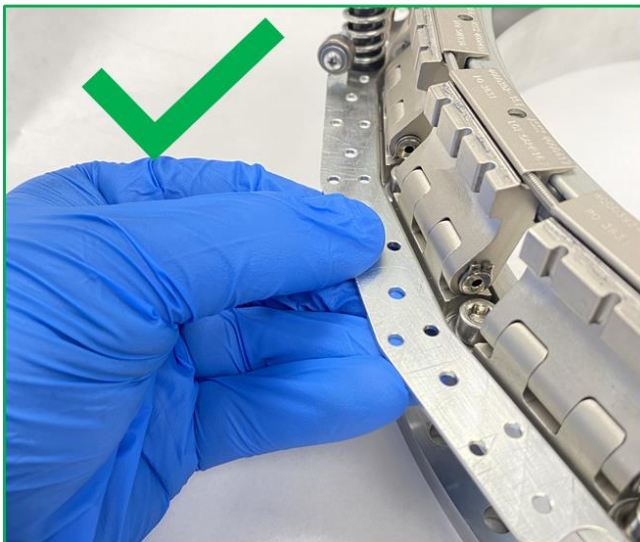

Figure 6-9: Uses flanges to handle the Lightband

7. Lightband Mechanical Attachment

Step	Procedure	Date & Initials	
		Tech.	QA
7.1.1	Ensure the SN on the Upper Ring corresponds to the SN on the Lower Ring. Record all Lightband info on the cover page. The assembly number and revision can be found on both the Upper and Lower Rings, typically adjacent the Motor Bracket Assembly. PSC document <i>3000224 MLB Training Record</i> also lists the MLB sizes and numbers.		
7.1.2	The Lightband is designed to accommodate 0.25 inch socket head cap (SHC) screws and small pattern washers (< 0.50 inch OD). Have ready the required tools and hardware necessary to attach the Lightband to both upper and lower adjoining structures. See Table 3-3 and Section 15 for equipment.		----N/A----
7.1.3	Verify the flatness of the Lower Ring's adjoining structure complies with the most recent version of PSC document <i>2000785 MkII MLB User Manual</i> . See note 1 below. Structure Description: _____ Required Flatness [in]: _____ Measured Flatness [in]: _____		
7.1.4	Verify the flatness of the Upper Ring's adjoining structure complies with the most recent version of PSC Document <i>2000785 MkII MLB User Manual</i> . See note 1 below. Structure Description: _____ Required Flatness [in]: _____ Measured Flatness [in]: _____		

- 1) Measured Flatness is the final assembled flatness, not the flatness of the individual part. Assembly will often warp structures so it is imperative to measure flatness after assembly. Measurement does not have to be real-time. Referencing a prior inspection is acceptable provided it was for the identical configuration.

Step	Procedure	Date & Initials	
		Tech.	QA
7.1.5	After attachment, the Lower and Upper Rings must meet the circularity requirement (may be specified as bolt circle tolerance) in PSC document <i>2000785 MkII MLB User Manual</i> and Step 7.1.13. Plan out the method that will be used to ensure the requirement is met. Also ensure the circularity of both adjoining structure bolt circle patterns is known. Forcing the Lightband to align with non-circular mounting holes will cause an anomaly. Some alignment method examples are <ul style="list-style-type: none"> • Using flat head alignment screws into an adjoining structure with threaded holes (structure's bolt circle circularity must be known to meet requirement) • Using 3X or more gage pins to maintain circularity during attachment (structure's bolt circle circularity must be known to meet requirement and thru holes must of similar size as Lightband, ~.281 in) • Using calipers or a CMM to measure diametric distance across Lower Ring and Upper Ring flanges after attachment. What method will be used to ensure circularity? _____		----N/A----

Step	Procedure	Date & Initials	
		Tech.	QA
7.1.6	Will Separation Switches or Separation Connectors be attached to the Lightband? If so, carefully review PSC documents <i>2001025 Separation Connector Data Sheet</i> and <i>2002204 Separation Switch Data Sheet</i> for unique attachment requirements. Also ensure sufficient tool access will be available as adjoining structures often overhang the Lightband and restrict access.		----N/A----
7.1.7	The mating surfaces of both adjoining structures and the Lightband interface surfaces shall be visibility clean, to the normal unaided eye, of all particulate matter and non-particulate film matter. If not, clean with isopropanol soaked lint free wipes.		
7.1.8	Lower Ring attachment to adjoining structure for all Lightbands except the MLB 15.000-24 (unless using reduced head fasteners). Place the Lower Ring on the adjoining structure. Insert fasteners and washers through mounting holes. It is often easier to place the washer on the Lower Ring prior to inserting the screw. Tighten fasteners until hand tight. See Figure 7-2 & Figure 7-4. Then skip to step 7.1.10.		
7.1.9	Lower Ring attachment to adjoining structure for the MLB 15.000-24 only. (If using reduced head fasteners per section 15 follow step 7.1.8 instead.) The spacing between Leaves is tight and requires a unique attachment procedure. <ol style="list-style-type: none"> 1. Elevate the Lower Ring off the table. This will permit the screws to protrude below. 2. Place only the washer on the Lower Ring. 3. Insert the screw. If the screw head rubs, push on each adjacent Leaf Pin to move it out of the way slightly. 4. If the adjoining structure has through holes place the Lower Ring on the structure allowing all screws to drop in the holes. 5. If the adjoining structure has threaded holes, the screws must be threaded gradually. Work around the Lightband, turning each screw a few turns at a time until hand tight. Take care to prevent the screw heads from jamming up into the Leaf Pins. See Figure 7-1 to Figure 7-4.		



Figure 7-1: Pushing Leaf Pin to side to make room for SHC screw (15.000-24 only).

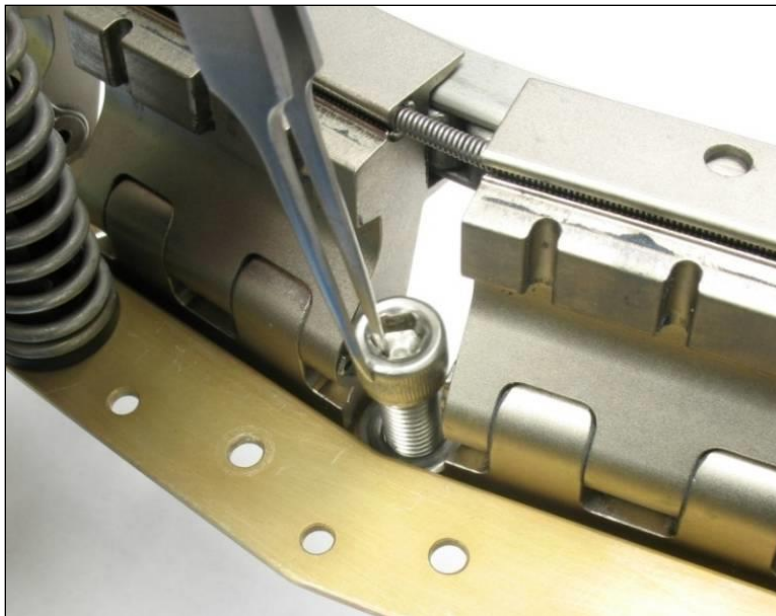

Figure 7-2: Inserting a SHC screw between Leaves on Lower Ring.



Figure 7-3: SHC screw and washer inserted between Leaves on elevated Lower Ring.

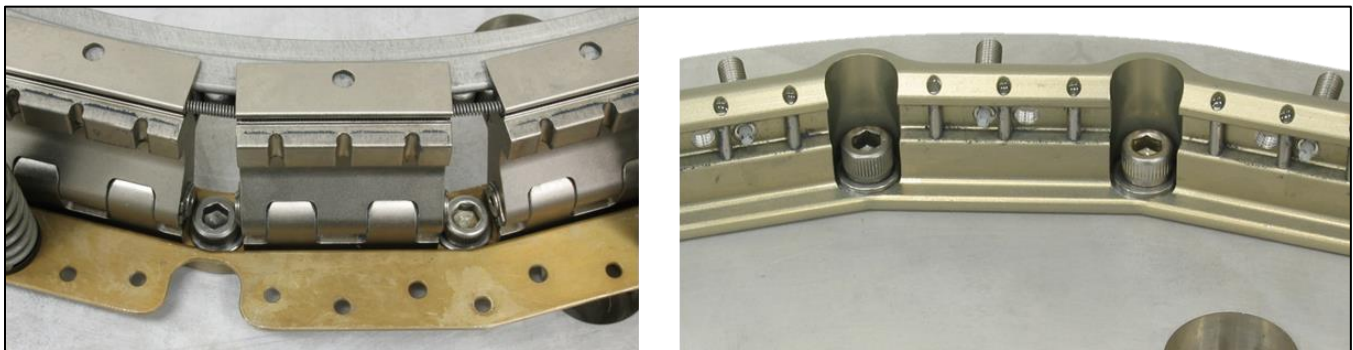

Figure 7-4: Separated Lightband halves attached to adjoining structures.

Step	Procedure	Date & Initials																						
		Tech.	QA																					
7.1.10	Torque all fasteners on the Lower Ring. Minimum allowable torque is 70 in·lb. PSC typically torques 100 to 115 in·lb. Higher torque is allowable for high line-loading. See note 2.																							
7.1.11	Attach the Upper Ring to its adjoining structure by inserting fasteners and washers through the counterbores. Tighten fasteners until hand tight. Do not contact the Lightband with the wrench. See Figure 7-4.																							
7.1.12	Torque all fasteners on the Upper Ring. Minimum allowable torque is 70 in·lb. PSC typically torques 100 to 115 in·lb. Higher torque is allowable for high line-loading. See note 2.																							
7.1.13	<p>Verify the circularity of both the Lower and Upper Rings complies with PSC document <i>2000785 MkII MLB User Manual</i>. Measurement frequency shall be sufficient to ensure minimum and maximum diameters are determined. See note 3 and Figure 7-5. Record results below.</p> <table border="1"> <thead> <tr> <th>Parameter</th> <th>Lower Ring</th> <th>Upper Ring</th> </tr> </thead> <tbody> <tr> <td>Stated bolt circle diameter, nom [in]</td> <td></td> <td></td> </tr> <tr> <td>Circularity tolerance, ±tol [in]</td> <td></td> <td></td> </tr> <tr> <td>Minimum measured value, min [in]</td> <td></td> <td></td> </tr> <tr> <td>Maximum measured value, max [in]</td> <td></td> <td></td> </tr> <tr> <td>Difference, max-min [in]</td> <td></td> <td></td> </tr> <tr> <td>All requirements met?</td> <td></td> <td></td> </tr> </tbody> </table>	Parameter	Lower Ring	Upper Ring	Stated bolt circle diameter, nom [in]			Circularity tolerance, ±tol [in]			Minimum measured value, min [in]			Maximum measured value, max [in]			Difference, max-min [in]			All requirements met?				
Parameter	Lower Ring	Upper Ring																						
Stated bolt circle diameter, nom [in]																								
Circularity tolerance, ±tol [in]																								
Minimum measured value, min [in]																								
Maximum measured value, max [in]																								
Difference, max-min [in]																								
All requirements met?																								

- 2) Customer shall always perform a thorough bolted-joint analysis to ensure sufficient margin on material strength, joint slipping and joint gapping.
- 3) If measuring a feature other than the bolt circle diameter, e.g. the distance across diametrically opposing flanges, the difference between the minimum and maximum values shall correspond to the total circularity tolerance. For example, a circularity tolerance of $\pm X$ implies the flange difference, max-min, shall be $\leq 2X$.

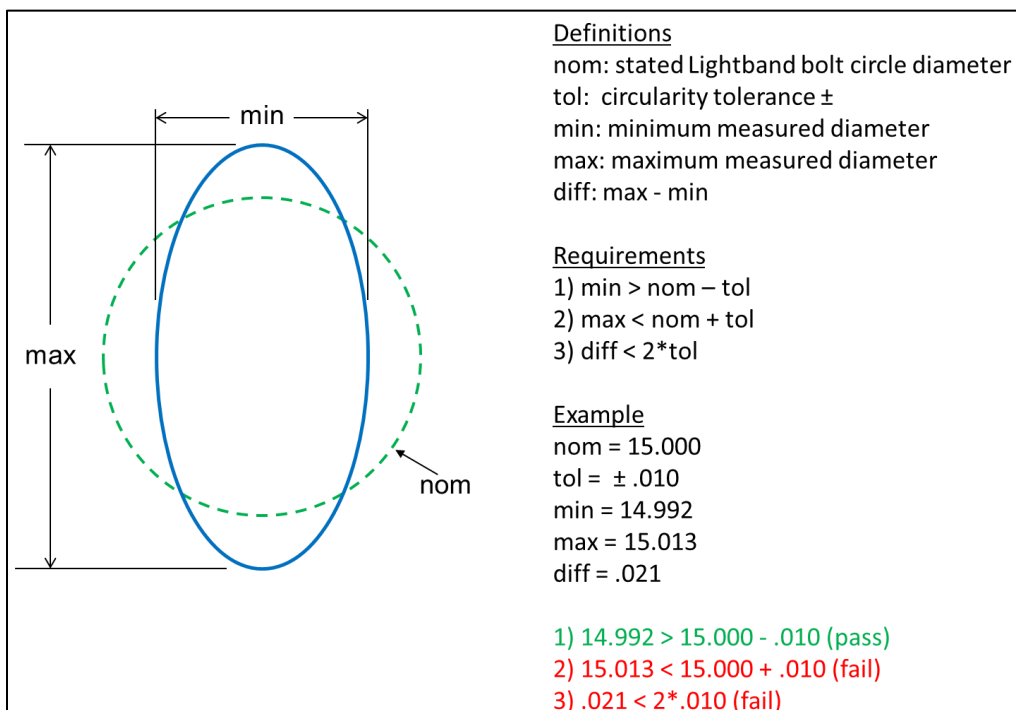
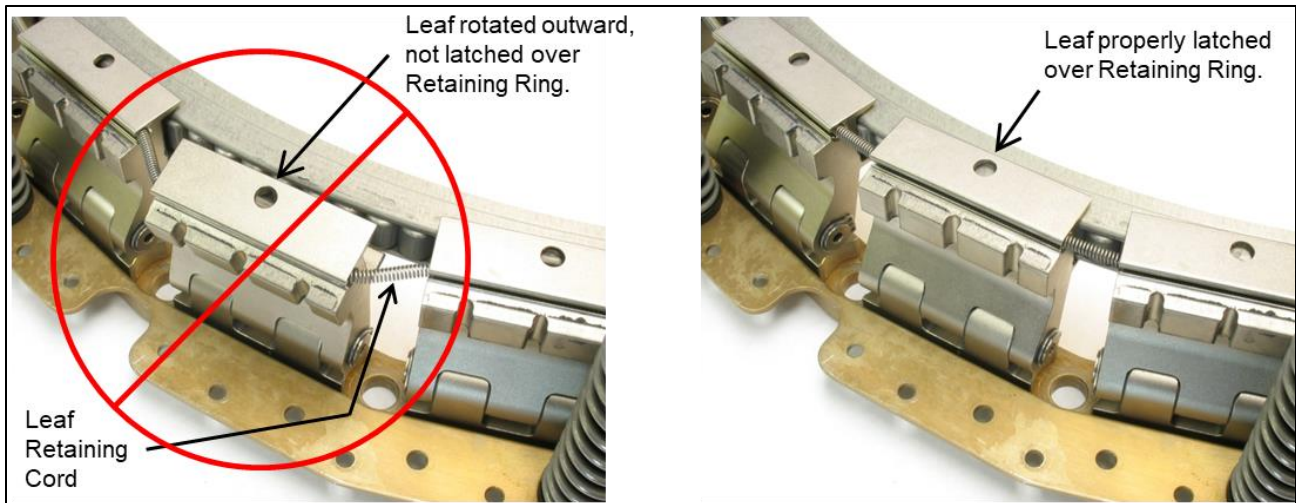

Figure 7-5: Circularity example

8. Mating the Lightband

Step	Procedure	Date & Initials	
		Tech.	QA
8.1.1	Verify the Upper and Lower Rings are attached to adjoining structures per Section 7. Also see section 4 warning #4.		
8.1.2	Orient the Lightband such that the wiring will reach the DB-9 electrical connector. Also ensure 1 ft minimum radial clearance around the Lightband for pre-Stow distance measurements.		-----N/A-----
8.1.3	Inspect the Lightband to verify: <ol style="list-style-type: none"> 1. It is visually free from damage. 2. All Hinged Leaves are properly latched over the Retaining Ring. See Figure 8-1 for proper orientation. 3. The Leaf Retaining Cord is seated in the groove of every Hinged Leaf. 		
8.1.4	Verify the Sliding Tube can move fully radially inward such that it contacts the Motor Bracket Deploy hard stops per Figure 8-2. If it cannot, proceed to step 8.1.5.		



a) Incorrect Leaf position.

b) Correct Leaf position.

Figure 8-1: Verifying Leaf positions

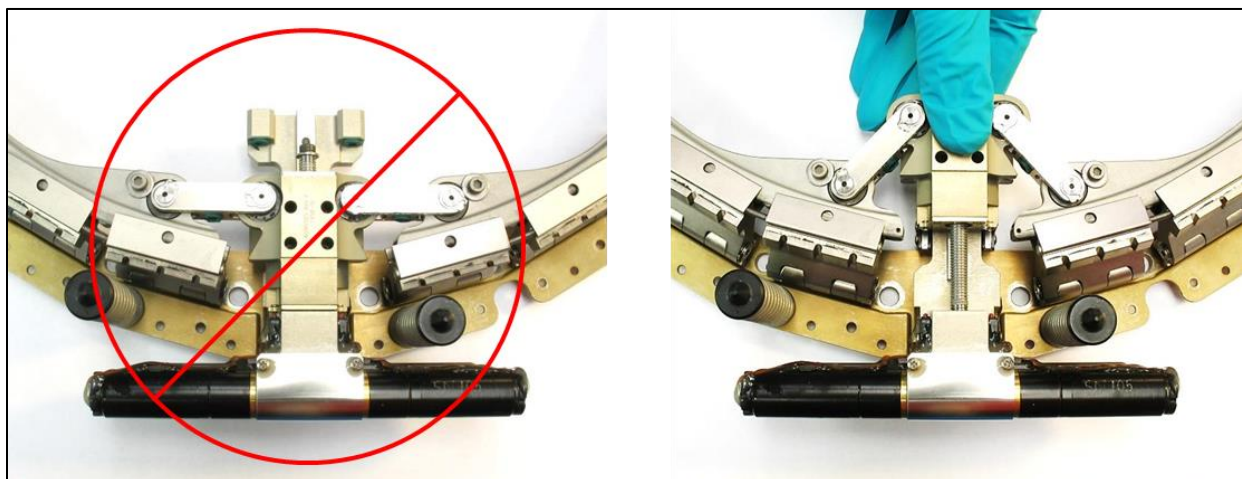

a) Incorrect position (Stowed)

b) Correct position (Deployed)

Figure 8-2: Verifying pre-Mate Sliding Tube position

Step	Procedure	Date & Initials	
		Tech.	QA
8.1.5	<p>This step shall only be performed if required by Step 8.1.4. This is typically only necessary prior to the first mate (after unpacking the Lightband).</p> <ol style="list-style-type: none"> 1. Contacting only the top surfaces, push the Sliding Tube radially outward (towards the motors). 2. Then, while maintaining force on the Sliding Tube, use a 7/64 inch hex key to rotate the ball screw clockwise as shown in Figure 8-3. The Ball screw should rotate smoothly with very low running torque. If torque exceeds 1 in·lb, stop and investigate. 3. Continue rotating the ball screw until there is approximately a 0.1 inch gap between the Sliding Tube and Motor Bracket as shown in Figure 8-4. Note this will require approximately 35 full revolutions. 		



Figure 8-3: Rotating ball screw to allow Sliding Tube travel

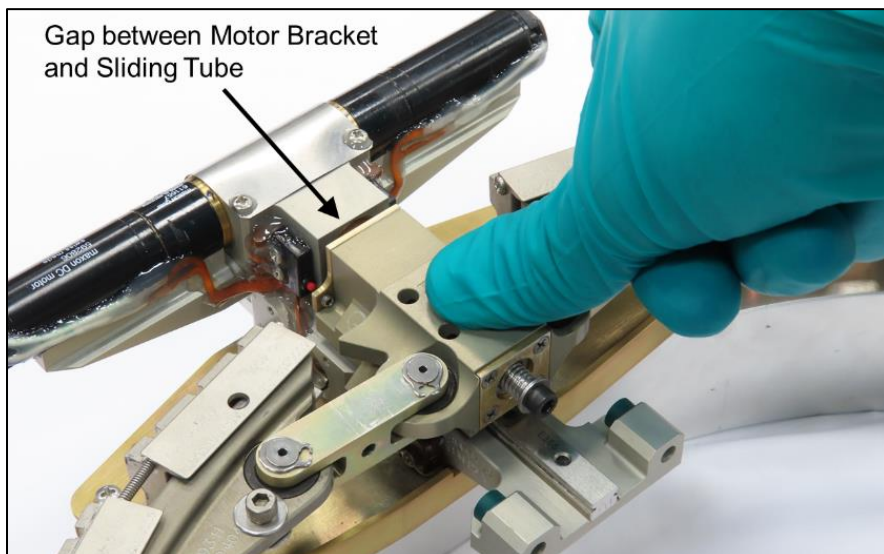

Figure 8-4: Gap after rotating ball screw

Step	Procedure	Date & Initials	
		Tech.	QA
8.1.6	Consider how the Lightband will be compressed. The Separation Springs may be distributed asymmetrically around the Lightband to induce tip-off or compensate for an offset CG. In this case using a central single compression point may not be adequate. Lightband Compression Tools (LCTs) are effective. See section 18 for details.		----N/A----
8.1.7	For horizontal integration, skip to Section 13.		----N/A----
8.1.8	Verify the system being used to compress the Lightband has a total axial (X_{LB}) stiffness less than 2,000 lb/in (the entire loop from the Upper Ring around to the Lower Ring). This applies to a crane system offloading a mass, a compression clamp fixture, etc. An isolation system (if attached to the Lightband) can be included in this stiffness calculation. See Figure 8-5. This compliance ensures the Lightband is able to self-align while Stowing. If the system is overly stiff, the Lightband motors will not be able to impart the necessary power required to quickly move the Upper Ring into alignment.		

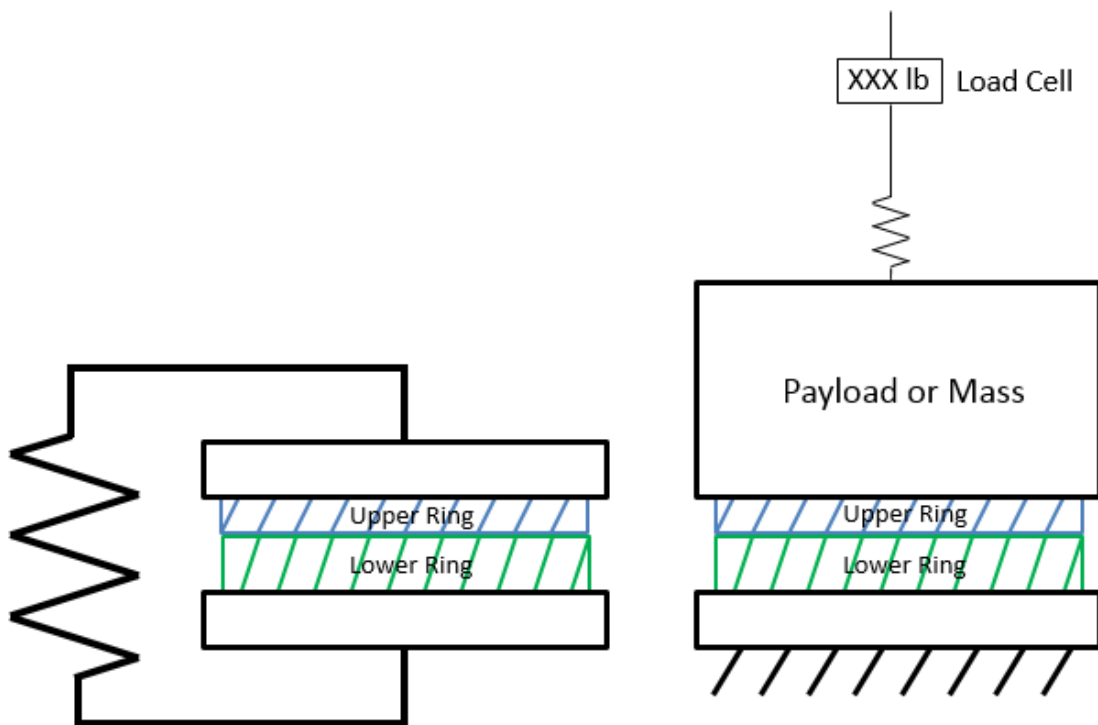

Figure 8-5: Verifying compliance in Lightband compression system. Two common methods shown.

Step	Procedure	Date & Initials	
		Tech.	QA
8.1.9	Verify the lateral (Y_{LB} & Z_{LB}) stiffness between the Upper and Lower Rings is less than 100 lb/in. This compliance ensures the Lightband can self-align while Stowing. If the system is overly stiff, the Lightband motors will not be able to impart the necessary power required to quickly move the Upper Ring into alignment.		
8.1.10	Ensure the Lower Ring is on a stable and visually level surface.		

Step	Procedure	Date & Initials	
		Tech.	QA
8.1.11	<p>Move the Upper Ring close to the Lower Ring for alignment checks. Verify alignment before any force is applied to compress the Lightband.</p> <p>Per Figure 8-6 ensure:</p> <ol style="list-style-type: none"> 1. Cutout in Upper Ring aligns over Motor Bracket Assembly on Lower Ring. 2. All Separation Connector/Switch cutouts align. 3. All Separation Spring tips protrude through appropriate holes in the Upper Ring. <p>Note if using a crane to lower a payload, perform all crane adjustments with the Upper Ring entirely above the Separation Spring tips to prevent damage due to excess crane movement.</p>		

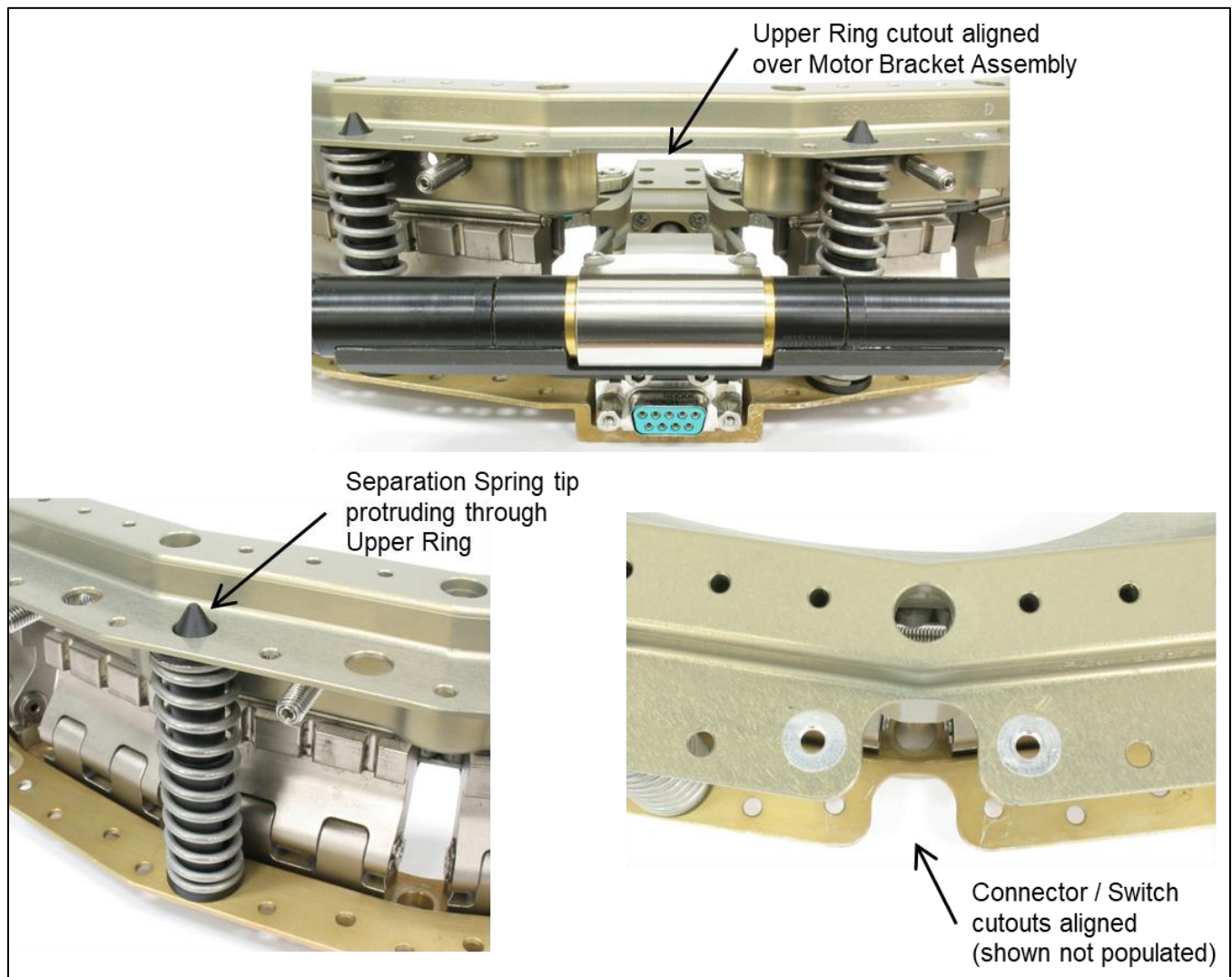

Figure 8-6: Aligning the Lower and Upper Rings.

Step	Procedure	Date & Initials	
		Tech.	QA
8.1.12	If using LCTs ensure they are properly attached per section 18.2 then proceed to section 18.3.		-----N/A-----
8.1.13	<p>Compress the Lightband. This can be achieved by placing weights on the Upper Ring, using the weight of the payload, compressing in a fixture, etc. The total applied force shall be within the range calculated below.</p> <p>Separation Spring quantity = _____</p> <p>Minimum force = ____ Springs x 20 lb = ____ lb</p> <p>Maximum force = ____ Springs x 30 lb = ____ lb</p> <p>Apply the force gradually and verify all Hinged Leaves rotate inside the Upper Ring as it compresses.</p> <p>Stop once the minimum force is applied.</p>		
8.1.14	<p>Once the minimum compressive force has been applied, verify the Lightband is properly compressed. Figure 8-7 shows a cross section of the Stowed Lightband. Verify the pre-Stow flange distance in at least 6 locations evenly spaced around the Lightband.</p> <p>If any measurement is not in specification verify proper alignment and compressive force. The force center may to be translated slightly to better align with the Separation Springs' net center of force. Increase compressive force as necessary, up to the maximum allowable per Step 8.1.13, until all measurements are in specification</p>		

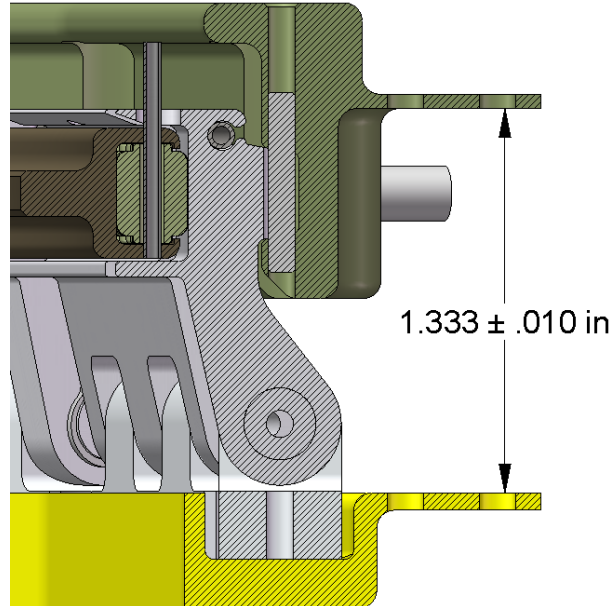

Figure 8-7: Lightband pre-Stow distance

9. Stowing the Lightband

This section will Stow the Lightband. During the Stow operation the Lightband's internal switches experience three collective switch states. Prior to Stowing, three test circuits will be operated to verify proper power and data acquisition. Emulating each switch state reduces the probability of an anomaly. In order, the states are

1. Deployed (full voltage and current draw for entire duration)
2. Intermediate (full voltage and current draw for entire duration)
3. Stowed (no voltage or current draw as this state emulates the stow switches cut power)

9.1 Stow Test Circuit #1 (Deployed State)

Step	Procedure	Date & Initials	
		Tech.	QA
9.1.1	Oscilloscope shall record voltage and current per the following requirements: <ol style="list-style-type: none"> 1. Sample rate: $\geq 1,000$ Hz 2. Voltage resolution: ≤ 0.2 V 3. Current resolution: ≤ 0.02 A 		----N/A----
9.1.2	Set up the <i>Stow Power and Measurement Circuit</i> portion of <i>Stow Test Circuit #1</i> per Figure 9-1.		
9.1.3	Excessively long harnesses and/or thin wires have significant resistance which will reduce the voltage at the motors. Verify the resistance between the power source and Lightband connector is acceptable. This applies to the complete loop (power and return). PSC recommends the following method <ol style="list-style-type: none"> 1. Ensure power source output is off. 2. Set the timer relay function to '<i>D: One Shot</i>' and 5 s duration. 3. Set a DMM to measure resistance and connect it across the power source. 4. Jumper pin 2 to pin 3 on a DB-9 socket connector and connect to the <i>Stow Power and Measurement Circuit</i>. 5. Activate the timer relay and read the DMM resistance measurement. It shall be $< 1.0 \Omega$. This verifies the Motor A portion of the circuit. 6. Remove the pin 2 to pin 3 jumper and connect pin 6 to pin 7. 7. Activate the timer relay and read the DMM resistance measurement. It shall be $< 1.0 \Omega$. This verifies the Motor B portion of the circuit. 8. Remove the jumper connector and DMM. 		
9.1.4	Set up the <i>Test Circuit: Deployed</i> portion of <i>Stow Test Circuit #1</i> per Figure 9-1 and connect to the <i>Stow Power and Measurement Circuit</i> .		

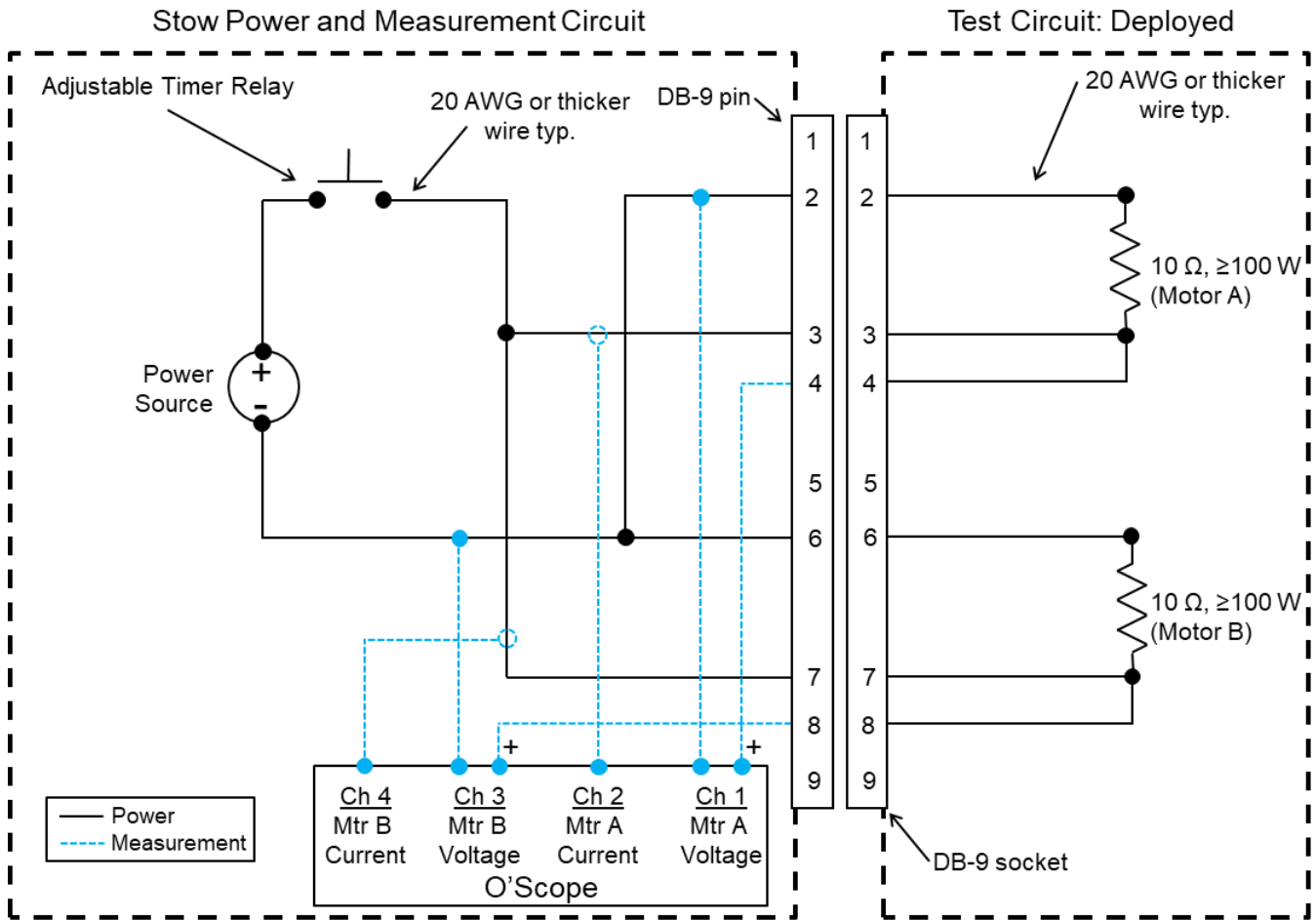

Figure 9-1: Stow test circuit #1

Step	Procedure	Date & Initials	
		Tech.	QA
9.1.5	Set the power source voltage according to Lightband size: Diameter < 31.0 inch: 27 to 28 V_{DC} Diameter ≥ 31.0 inch and greater: 30 to 31 V_{DC}		
9.1.6	Set the current limit on the power source to 6.5 ± 0.1 A.		
9.1.7	Set the timer relay to apply power for 1.50 ± 0.05 s. If using the recommended timer, set its function to ' <i>D: One Shot</i> '.		
9.1.8	Adjust oscilloscope to properly capture all channels. Verify <ol style="list-style-type: none"> 1. Current probe scale matches oscilloscope on Ch. 2 & 4 (10A/V on oscilloscope & 100 mA/V on current probes) 2. Current probes are zeroed 3. Voltage scales on Ch. 1 & 3 (recommend 5 V/div) 4. Vertical positions on Ch. 1 & 3 (recommend zero at 1.5 div from bottom of screen) 5. Current scales on Ch. 2 & 4 (recommend 500 mA/div) 6. Vertical positions on Ch. 2 & 4 (recommend zero at 1 div from bottom of screen) 7. Horizontal time scale will capture entire duration (recommend 250 ms/div) 8. Horizontal trigger position (recommend 1 div from left of screen) 9. Vertical trigger level and channel (recommend Ch. 1 set to 2 V) 		
9.1.9	Perform the following to operate the test circuit. <ol style="list-style-type: none"> 1. Turn on the power source output. 2. Verify the oscilloscope trigger is active and ready to acquire data. 3. Activate the timer relay. 4. Verify the following occurred: <ol style="list-style-type: none"> 4.1. Voltage and current recorded per step 9.1.1 4.2. Measured voltage meets requirement in step 9.1.5 for Channels 1 & 3 4.3. Measured current values are approximately 1/10th of applied voltage for Channels 2 & 4 4.4. Timer relay applies power per step 9.1.7 4.5. Data saves and is readable on a computer 5. If positions or scales were altered to examine data, ensure they are returned to their original values. 6. Turn off the power source output. If any parameters are not met, make the required changes and repeat this step. Upon completion of this step, the <i>Stow Power and Measurement Circuit</i> shall not be changed.		
9.1.10	Remove the <i>Test Circuit: Deployed</i> portion of <i>Stow Test Circuit #1</i> in Figure 9-1.		-----N/A-----

9.2 Stow Test Circuit #2 (Intermediate State)

Step	Procedure	Date & Initials	
		Tech.	QA
9.2.1	Set up the <i>Test Circuit: Intermediate</i> portion of <i>Stow Test Circuit #2</i> per Figure 9-2 and connect to the <i>Stow Power and Measurement Circuit</i> .		

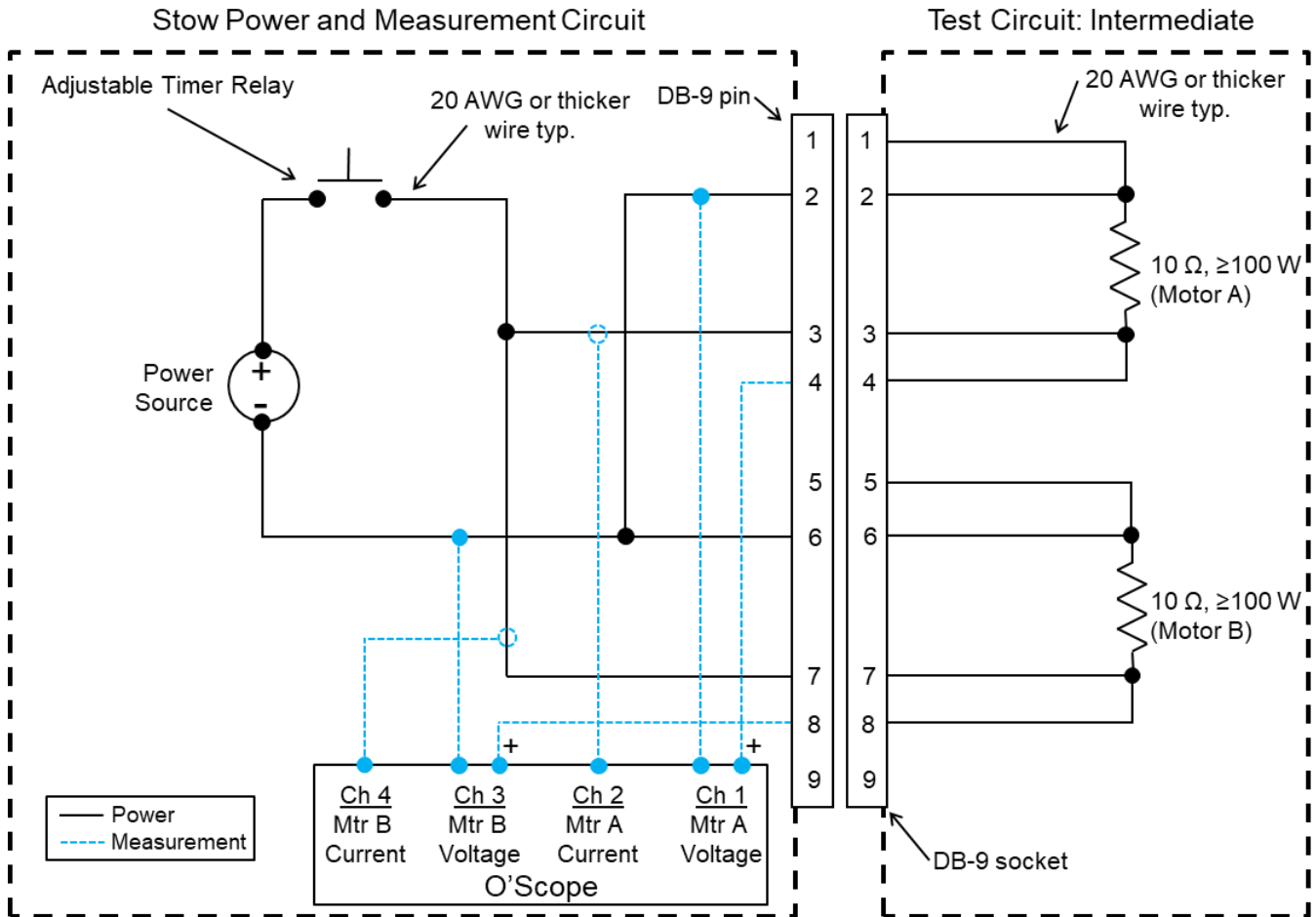

Figure 9-2: Stow test circuit #2

Step	Procedure	Date & Initials	
		Tech.	QA
9.2.2	<p>Perform the following to operate the test circuit.</p> <ol style="list-style-type: none"> 1. Turn on the power source output. 2. Verify the oscilloscope trigger is active and ready to acquire data. 3. Activate the timer relay. 4. Verify the following occurred: <ol style="list-style-type: none"> 4.1. Voltage and current recorded per step 9.1.1 4.2. Measured voltage meets requirement in step 9.1.5 for Channels 1 & 3 4.3. Measured current values are approximately 1/10th of applied voltage for Channels 2 & 4 4.4. Timer relay applies power per step 9.1.7 4.5. Data saves and is readable on a computer 5. If positions or scales were altered to examine data, ensure they are returned to their original values. 6. Turn off the power source output. <p>If any parameters are not met, make the required changes and repeat this step. Any change to the <i>Stow Power and Measurement Circuit</i> shall also require re-running <i>Stow Test Circuit #1</i> per section 9.1.</p>		
9.2.3	Remove the <i>Test Circuit: Intermediate</i> portion of <i>Stow Test Circuit #2</i> in Figure 9-2.		----N/A----

9.3 Stow Test Circuit #3 (Stowed State)

Step	Procedure	Date & Initials	
		Tech.	QA
9.3.1	Set up the <i>Test Circuit: Stowed</i> portion of <i>Stow Test Circuit #3</i> per Figure 9-3 and connect to the <i>Stow Power and Measurement Circuit</i> .		

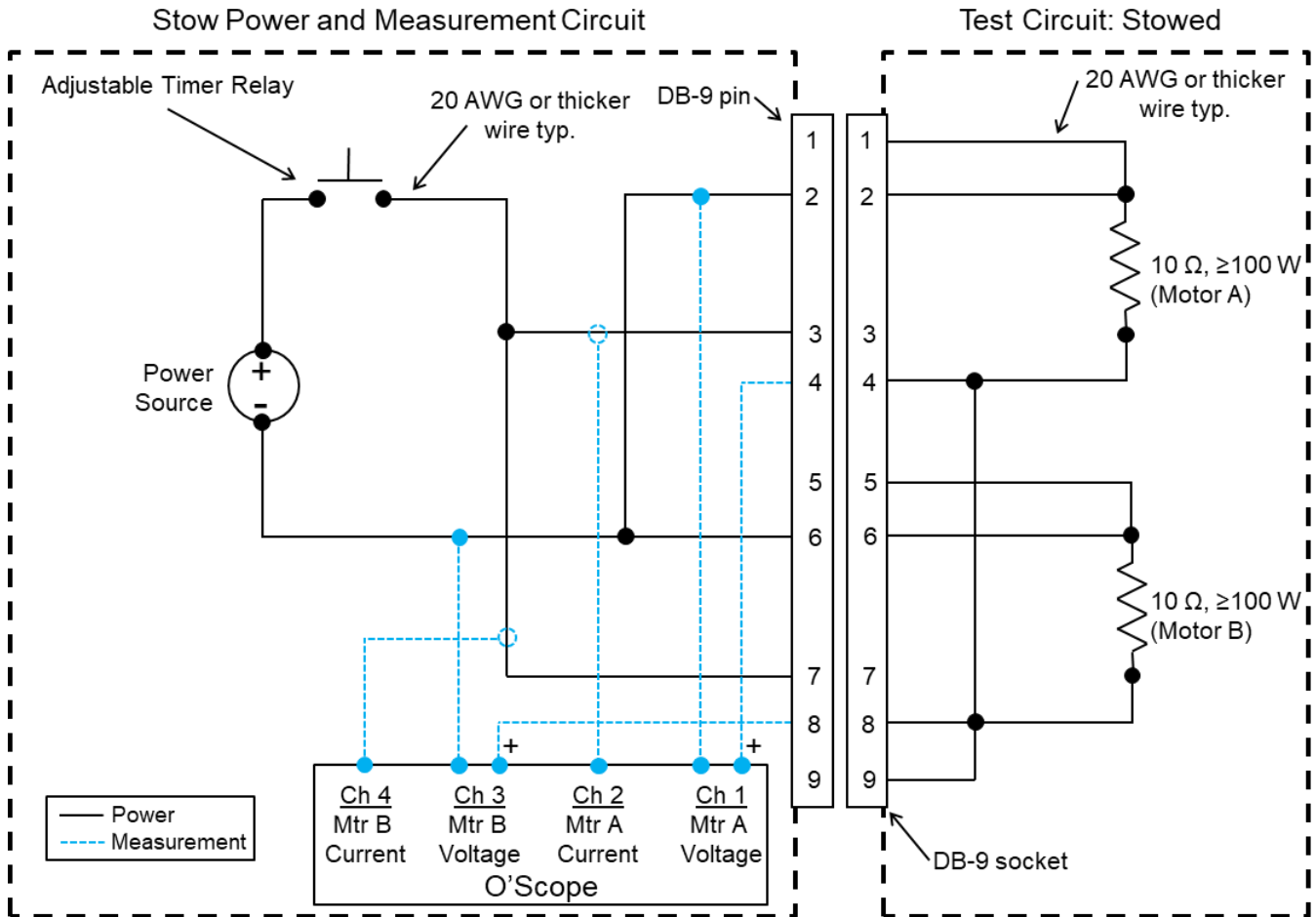

Figure 9-3: Stow test circuit #3

Step	Procedure	Date & Initials	
		Tech.	QA
9.3.2	<p>Perform the following to operate the test circuit.</p> <ol style="list-style-type: none"> 1. Designate a person to watch the power source output display. 2. Turn on the power source output. 3. Verify the oscilloscope trigger is active and ready to acquire data. 4. Activate the timer relay. 5. Verify the following occurred: <ol style="list-style-type: none"> 5.1. All four measurement channels (voltage and current) remained at zero. The oscilloscope should not trigger. 5.2. The power source's current indicator remained at zero. This ensures even a small voltage or current, below the oscilloscope's trigger level, did not pass through. 6. If positions or scales were altered to examine data, ensure they are returned to their original values. 7. Turn off the power source output. <p>If any parameters are not met, make the required changes and repeat this step. Any change to the <i>Stow Power and Measurement Circuit</i> shall also require re-running <i>Stow Test Circuit #1</i> per section 9.1 and <i>Stow Test Circuit #2</i> per section 9.2.</p>		
9.3.3	Remove the <i>Test Circuit: Stowed</i> portion of <i>Stow Test Circuit #3</i> in Figure 9-3.		-----N/A-----

9.4 Stow

Step	Procedure	Date & Initials	
		Tech.	QA
9.4.1	Verify the DB-9 pin connector of the <i>Stow Power and Measurement Circuit</i> in Figure 9-4 is visibly clean. Any debris could detrimentally contaminate the Lightband's mating socket connector.		
9.4.2	Connect the Lightband to the <i>Stow Power and Measurement Circuit</i> per Figure 9-4. Do not apply power to the Lightband.		

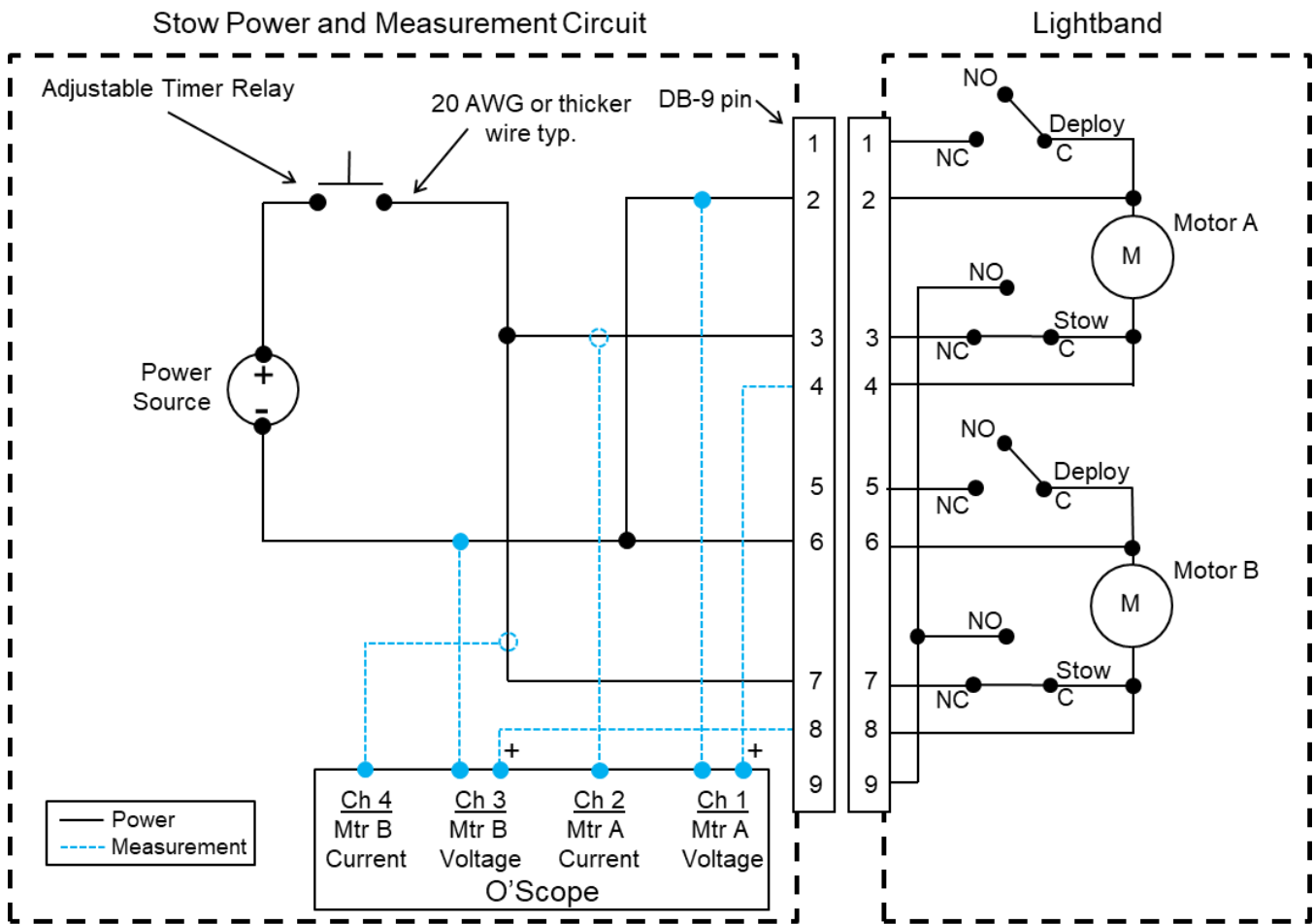

Figure 9-4: Stow circuit

Step	Procedure	Date & Initials	
		Tech.	QA
9.4.3	Prior to Stowing, verify the Lightband is in the allowable temperature range per section 4, note 10.		
9.4.4	Re-verify pre-Stow flange distance still complies with step 8.1.14. If it does not, repeat step 8.1.14 (or step 18.3.5 if using LCTs). This ensures weights did not shift or LCTs did not creep as there is often significant time between the previous measurement and this step.		
9.4.5	PSC recommends recording video and audio of the Stow operation. This is not required but has proven very helpful in determining root cause in the unexpected event of an anomaly.		----N/A----
9.4.6	<p>To Stow the Lightband:</p> <ol style="list-style-type: none"> 1. See Figure 9-5 and Table 9-1 for the anticipated current draw and power duration. 2. Designate a person to watch the power source output display. 3. Turn on the power source output. 4. Verify the oscilloscope trigger is active and ready to acquire data. 5. Activate the timer relay. This will send power to the motors and Stow the Lightband. <p>Manually cut power if the current limit is reached or the timer relay runs longer than specified. Then contact PSC per section 5. A visual inspection of the Lightband may be performed, but do not change configuration.</p>		
9.4.7	Take a picture of the oscilloscope screen in case data inadvertently gets erased.		
9.4.8	Turn off the power source output.		
9.4.9	Save the voltage and current profiles for both motors and verify the data is readable.		
9.4.10	<p>Figure 9-5 shows example Stow voltage and current profiles. Complete Table 9-1 to verify all parameters are within tolerance. Single data point exceedances are acceptable. Also, a slow sample rate may alias data. Do not filter data. Contact PSC if a discrepancy is found.</p> <p>Remember to account for non-zero offsets in the voltage or current measurements.</p>		

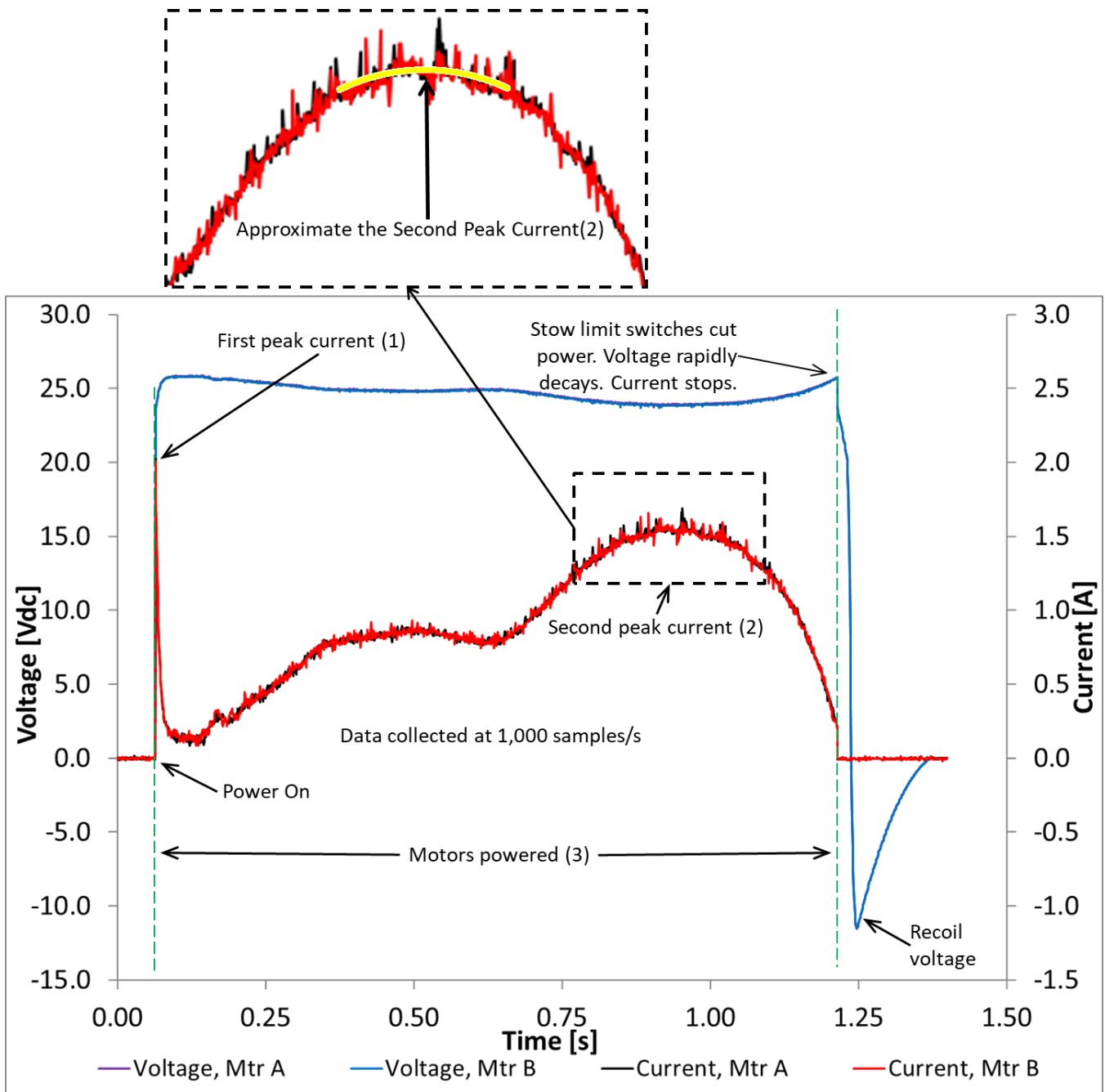

Figure 9-5: Example Stow voltage and current profiles at NTP

Table 9-1: Stow electrical verification (values apply at NTP)

Stow Electrical Parameters							
MLB Size	Item	Description (1)	Units	Allowable		Measured	
				Min	Max	Motor A	Motor B
8.000-12	1	First peak current	A/mtr	1.9	3.0		
	2	Second peak current	A/mtr	0.4	1.4		
	3	Motors powered duration	s	0.5	1.1		
11.732-18	1	First peak current	A/mtr	1.9	3.0		
	2	Second peak current	A/mtr	0.7	1.6		
	3	Motors powered duration	s	0.5	1.1		
13.000-20	1	First peak current	A/mtr	1.9	3.0		
	2	Second peak current	A/mtr	0.8	1.7		
	3	Motors powered duration	s	0.6	1.1		
15.000-24	1	First peak current	A/mtr	1.9	3.0		
	2	Second peak current	A/mtr	0.9	1.8		
	3	Motors powered duration	s	0.6	1.1		
18.250-28	1	First peak current	A/mtr	1.9	3.0		
	2	Second peak current	A/mtr	1.0	1.9		
	3	Motors powered duration	s	0.6	1.2		
19.848-28	1	First peak current	A/mtr	1.9	3.0		
	2	Second peak current	A/mtr	1.0	1.9		
	3	Motors powered duration	s	0.6	1.2		
23.250-32	1	First peak current	A/mtr	1.9	3.0		
	2	Second peak current	A/mtr	1.1	2.1		
	3	Motors powered duration	s	0.65	1.3		
24.000-36	1	First peak current	A/mtr	1.9	3.0		
	2	Second peak current	A/mtr	1.1	2.1		
	3	Motors powered duration	s	0.65	1.3		
31.600-48	1	First peak current	A/mtr	2.1	3.2		
	2	Second peak current	A/mtr	1.4	2.3		
	3	Motors powered duration	s	0.65	1.3		
38.810-60	1	First peak current	A/mtr	2.1	3.2		
	2	Second peak current	A/mtr	1.5	2.3		
	3	Motors powered duration	s	0.65	1.3		

(1) Use the current channels to determine *Motors powered duration*.

Step	Procedure	Date & Initials	
		Tech.	QA
9.4.11	Disconnect the <i>Stow Power and Measurement Circuit</i> in Figure 9-4 from the Lightband's DB-9 connector.		
9.4.12	<p>Measure resistance directly at the Lightband's DB-9 socket connector and complete Table 9-2. Contact PSC if a discrepancy is found.</p> <p>PSC recommends using a DMM. It will not cause damage to or operate the Lightband. If using a milliohm meter (four wire Kelvin probe system) ensure the test current is <0.01 A to prevent rotating the motors.</p> <p>See Figure 14-1 for the Stowed Motor Bracket Assembly switch state.</p> <p>Note: ensure the mating DB-9 pin connector is visibly clean to prevent contaminating the Lightband's socket connector.</p>		

Table 9-2: Stowed resistance measurements (values apply only at NTP)

Lightband State	Object Being Measured	Pin Connections	Resistance [Ω]	
			Allowable (1)	Measured
Stowed	Motor A	2 , 4	8.0 to 11.0	
	Motor B	6 , 8	8.0 to 11.0	
	Deploy Limit Switch A	1 , 2	< 0.3	
	Deploy Limit Switch B	5 , 6	< 0.3	
	Stow Limit Switch A	3 , 4	> 1E7	
	Stow Limit Switch B	7 , 8	> 1E7	
	Stow Limit Switch A	4 , 9	< 0.3	
	Stow Limit Switch B	8 , 9	< 0.3	

(1) Ensure the over limit (OL) indication on the resistance measurement device complies with the maximum tolerance. This is the case for the DMM referenced in Table 3-5.

Step	Procedure	Date & Initials	
		Tech.	QA
9.4.13	If weights or a fixture were used to compress the Lightband, they may be removed at this time. If LCTs were used, remove cable ties per section 18.5.		

10. Setting-For-Flight the Lightband

This section will Set-For-Flight (SFF) the Lightband. During the SFF operation the Lightband's internal switches experience two collective switch states. Prior to Setting-For-Flight, two test circuits will be operated to verify proper power and data acquisition. Emulating each switch state reduces the probability of an anomaly. In order, the states are

1. Stowed (full voltage and current draw for entire duration)
2. Intermediate (no voltage or current draw as this state emulates the stow switches cut power)

10.1 SFF Test Circuit #1 (Stowed State)

Step	Procedure	Date & Initials	
		Tech.	QA
10.1.1	Oscilloscope shall record voltage and current per the following requirements: <ol style="list-style-type: none"> 1. Sample rate: $\geq 1,000$ Hz 2. Voltage resolution: ≤ 0.2 V 3. Current resolution: ≤ 0.02 A 		-----N/A-----
10.1.2	Set up the <i>SFF Power and Measurement Circuit</i> portion of <i>SFF Test Circuit #1</i> per Figure 10-1. Caution: If oscilloscope channels share common ground be cognizant of their effect on the circuit (see section 17). Also, do not connect the negative voltage probe to ground as this will bypass the Lightband's limit switches and allow it to Deploy.		
10.1.3	May skip this step if no components/wiring were added since Stowing. Excessively long harnesses and/or thin wires have significant resistance which will reduce the voltage at the motors. Verify the resistance between the power source and Lightband connector is acceptable. This applies to the complete loop (power and return). PSC recommends the following method <ol style="list-style-type: none"> 1. Ensure power source output is off. 2. Set the timer relay function to '<i>D: One Shot</i>' and 5 s duration. 3. Set a DMM to measure resistance and connect it across the power source. 4. Jumper pin 1 to pin 9 on a DB-9 socket connector and connect to the <i>SFF Power and Measurement Circuit</i>. 5. Activate the timer relay and read the DMM resistance measurement. It shall be $< 1.0 \Omega$. This verifies the Motor A portion of the circuit. 6. Remove the pin 1 to pin 9 jumper and connect pin 5 to pin 9. 7. Activate the timer relay and read the DMM resistance measurement. It shall be $< 1.0 \Omega$. This verifies the Motor B portion of the circuit. 8. Remove the jumper connector and DMM. 		
10.1.4	Set up the <i>Test Circuit: Stowed</i> portion of <i>SFF Test Circuit #1</i> per Figure 10-1 and connect to the <i>SFF Power and Measurement Circuit</i> .		

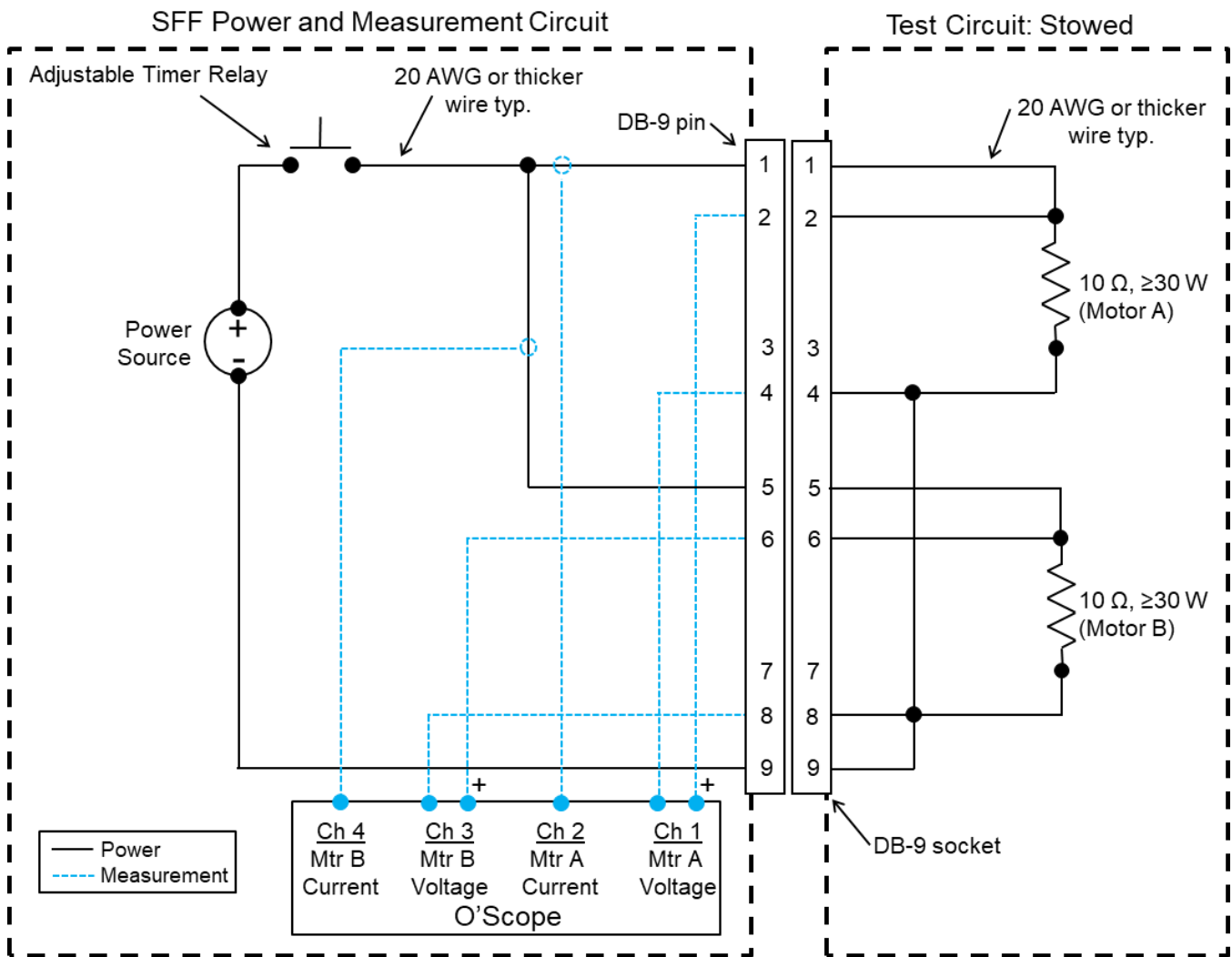

Figure 10-1: SFF test circuit #1

Step	Procedure	Date & Initials	
		Tech.	QA
10.1.5	Set the power source voltage at 15 to 16 V_{DC} .		
10.1.6	Set the current limit on the power source to 3.5 ± 0.1 A .		
10.1.7	Set the timer relay to apply power for 1.40 ± 0.05 s . If using the recommended timer, set its function to ' <i>D: One Shot</i> '.		
10.1.8	Adjust oscilloscope to properly capture all channels. Verify <ol style="list-style-type: none"> 1. Current probe scale matches oscilloscope on Ch. 2 & 4 (10A/V on oscilloscope & 100 mA/V on current probes) 2. Current probes are zeroed 3. Voltage scales on Ch. 1 & 3 (recommend 5 V/div) 4. Vertical positions on Ch. 1 & 3 (recommend zero at 3 div from bottom of screen) 5. Current scales on Ch. 2 & 4 (recommend 500 mA/div) 6. Vertical positions on Ch. 2 & 4 (recommend zero at 3 div from bottom of screen) 7. Horizontal time scale will capture entire duration (recommend 250 ms/div) 8. Horizontal trigger position (recommend 1 div from left of screen) 9. Vertical trigger level and channel (recommend Ch. 1 set to 2 V) 		
10.1.9	Perform the following to operate the test circuit. <ol style="list-style-type: none"> 1. Turn on the power source output. 2. Verify the oscilloscope trigger is active and ready to acquire data. 3. Activate the timer relay. 4. Verify the following occurred: <ol style="list-style-type: none"> 4.1. Voltage and current recorded per step 10.1.1 4.2. Measured voltage meets requirement in step 10.1.5 for Channels 1 & 3 4.3. Measured current values are approximately 1/10th of applied voltage for Channels 2 & 4 4.4. Timer relay applies power per step 10.1.7 4.5. Data saves and is readable on a computer 5. If positions or scales were altered to examine data, ensure they are returned to their original values. 6. Turn off the power source output. <p>If any parameters are not met, make the required changes and repeat this step. Upon completion of this step, the <i>SFF Power and Measurement Circuit</i> shall not be changed.</p>		
10.1.10	Remove the <i>Test Circuit: Stowed</i> portion of <i>SFF Test Circuit #1</i> in Figure 10-1.		----N/A----

10.2 SFF Test Circuit #2 (Intermediate State)

Step	Procedure	Date & Initials	
		Tech.	QA
10.2.1	Set up the <i>Test Circuit: Intermediate</i> portion of <i>SFF Test Circuit #2</i> per Figure 10-2 and connect to the <i>SFF Power and Measurement Circuit</i> .		

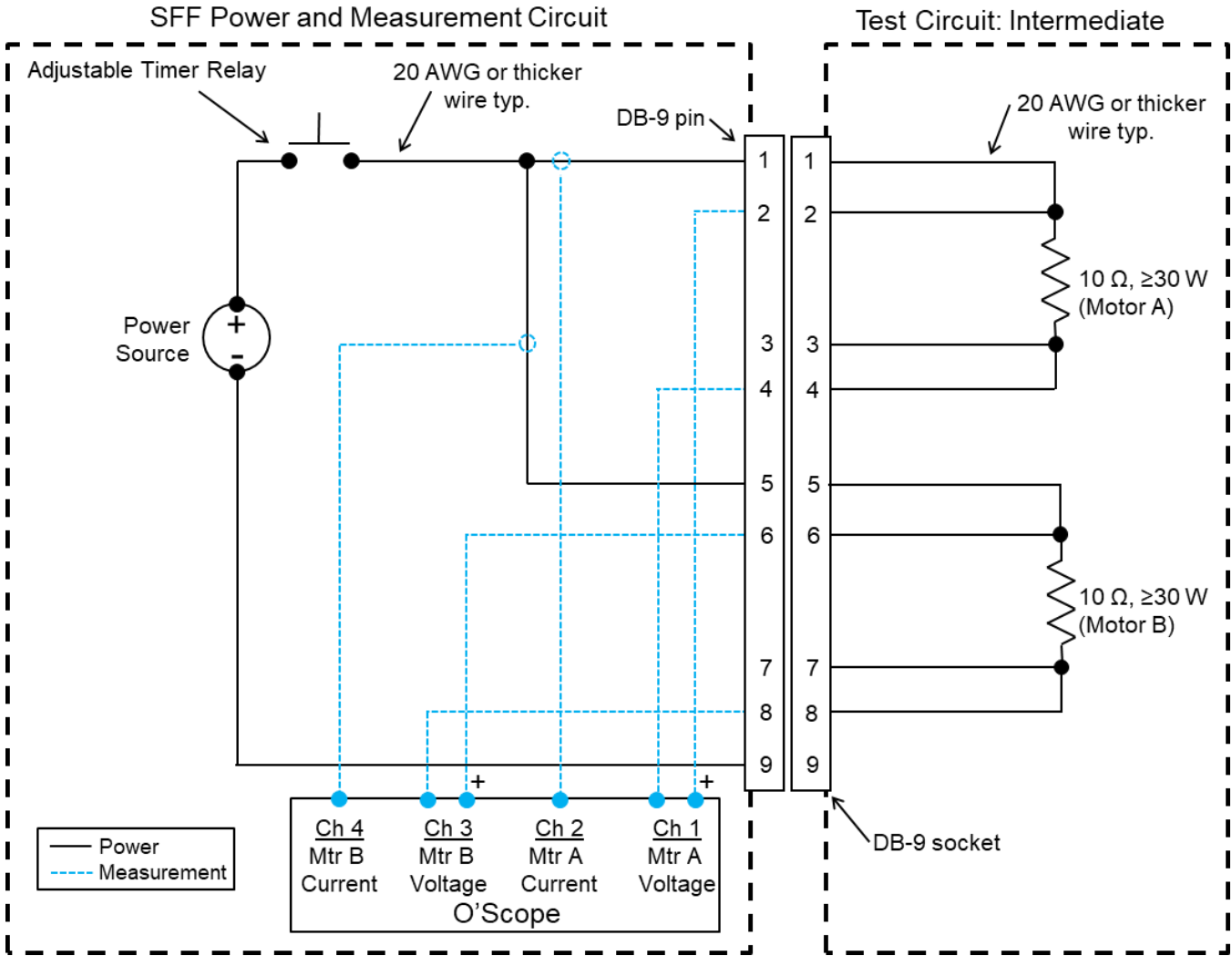

Figure 10-2: SFF test circuit #2

Step	Procedure	Date & Initials	
		Tech.	QA
10.2.2	<p>Perform the following to operate the test circuit.</p> <ol style="list-style-type: none"> 1. Designate a person to watch the power source output display. 2. Turn on the power source output. 3. Verify the oscilloscope trigger is active and ready to acquire data. 4. Activate the timer relay. 5. Verify the following occurred: <ol style="list-style-type: none"> 5.1. All four measurement channels (voltage and current) remained at zero. The oscilloscope should not trigger. 5.2. The power source's current indicator remained at zero. This ensures even a small voltage or current, below the oscilloscope's trigger level, did not pass through. 6. If positions or scales were altered to examine data, ensure they are set back to their original values. 7. Turn off the power source output. <p>If any parameters are not met, make the required changes and repeat this step. Any change to the <i>SFF Power and Measurement Circuit</i> shall also require re-running <i>SFF Test Circuit #1</i> per section 10.1.</p>		
10.2.3	Remove the <i>Test Circuit: Intermediate</i> portion of <i>SFF Test Circuit #2</i> in Figure 10-2.		----N/A----

10.3 Set-For-Flight

Step	Procedure	Date & Initials	
		Tech.	QA
10.3.1	Verify the DB-9 pin connector of the <i>SFF Power and Measurement Circuit</i> in Figure 10-3 is visibly clean. Any debris could detrimentally contaminate the Lightband's mating socket connector.		
10.3.2	Connect the Lightband to the <i>SFF Power and Measurement Circuit</i> per Figure 10-3. Do not apply power to the Lightband.		

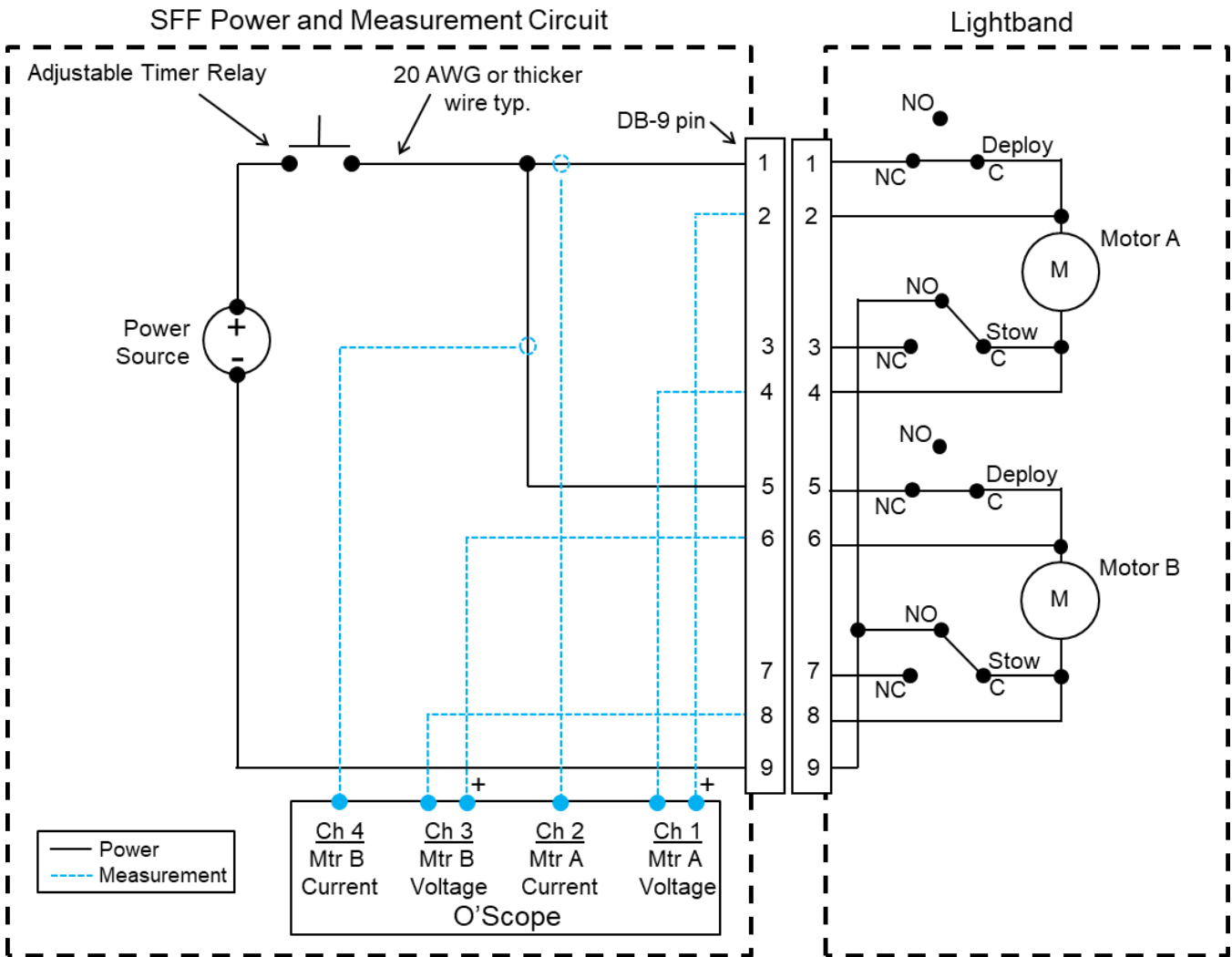

Figure 10-3: SFF circuit

Step	Procedure	Date & Initials	
		Tech.	QA
10.3.3	PSC recommends recording video and audio of the Set-For-Flight operation. This is not required but has proven very helpful in determining root cause in the unexpected event of an anomaly.		-----N/A-----
10.3.4	<p>To Set-For-Flight the Lightband:</p> <ol style="list-style-type: none"> 1. See Figure 10-4 and Table 10-1 for the anticipated current draw and power duration. 2. Designate a person to watch the power source output display. 3. Turn on the power source output. 4. Verify the oscilloscope trigger is active and ready to acquire data. 5. Activate the timer relay. This will send power to the motors and Set-For-Flight the Lightband. The drivetrain will free run for ~1.1 s and then the Sliding Tube will move off the Stow limit switches. This will be apparent via one or more of the following <ol style="list-style-type: none"> a) the current spikes b) the Sliding Tube begins to rapidly move off and on the Motor Bracket c) an audible chatter emanates from the Motor Bracket Assembly (the chatter is the electro-mechanical natural frequency of the Motor Bracket Assembly) <p>Manually cut power if the current limit is reached or the timer relay runs longer than specified. Then contact PSC per section 5. A visual inspection of the Lightband may be performed, but do not change configuration.</p> <p>Caution: See note 1 below.</p>		
10.3.5	Take a picture of the oscilloscope screen in case data inadvertently gets erased.		
10.3.6	Turn off the power source output.		
10.3.7	Save the voltage and current profiles for both motors and verify the data is readable.		
10.3.8	<p>Figure 10-4 shows example Set-For-Flight voltage and current profiles. Complete Table 10-1 to verify all parameters are within tolerance. Single data point exceedances are acceptable. Also, a slow sample rate may alias data. Do not filter data. Contact PSC if a discrepancy is found.</p> <p>Remember to account for non-zero offsets in the voltage or current measurements.</p>		

(1) If using an oscilloscope with common ground the negative voltage probes at pins 4 and 8 are connected. The current flow can bypass one of the Stow limit switches. Therefore, both Stow limit switches must open before power is cut. This will manifest itself in the current profile as both motors being perfectly synced, when in reality there may be switch activation differences of a few milliseconds. See Section 17 for details.

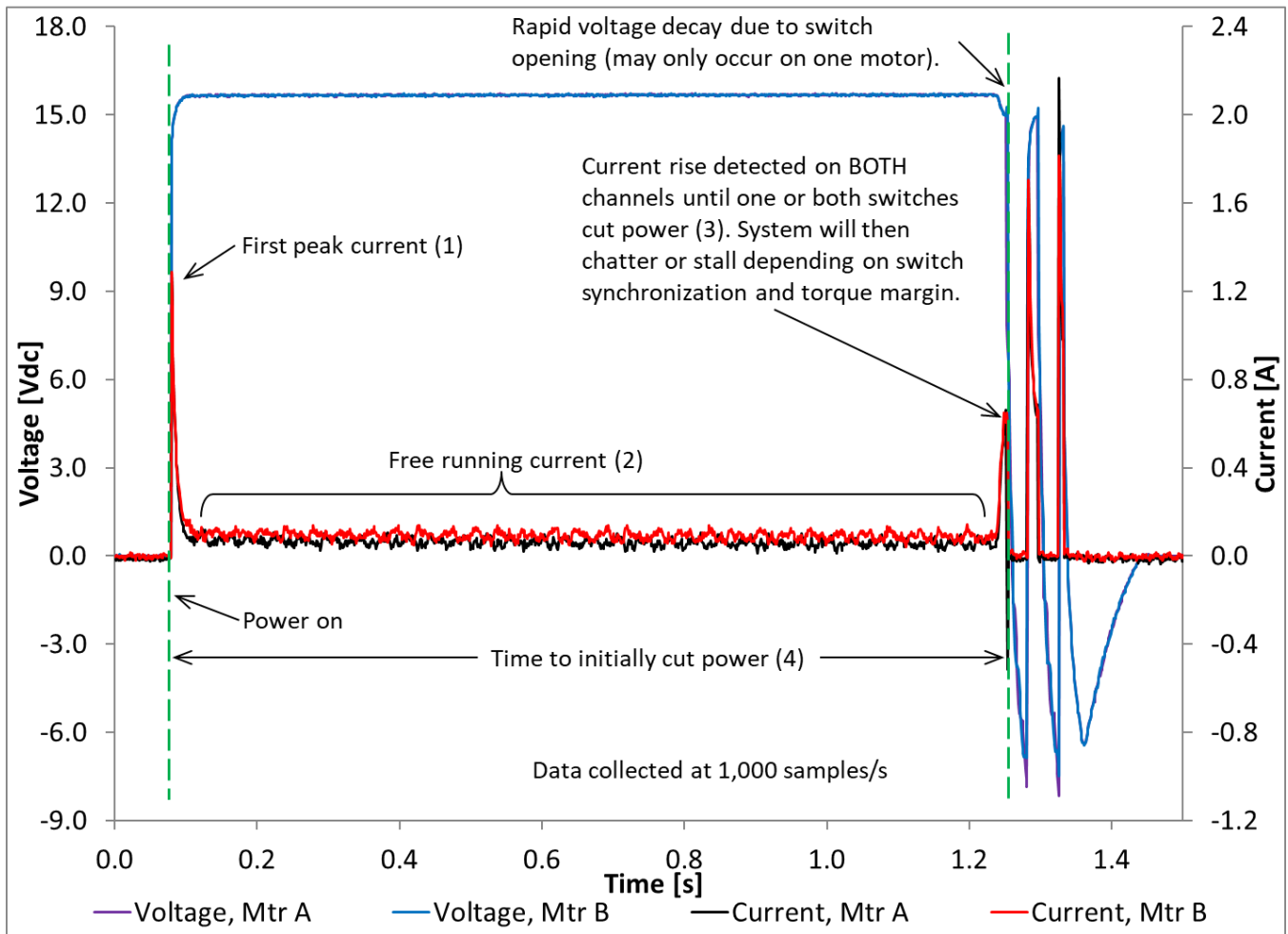

Figure 10-4: Example Set-For-Flight voltage and current profiles at NTP

Table 10-1: Set-For-Flight electrical verification (values apply only at NTP)

Set-For-Flight Electrical Parameters						
Item	Description	Units	Allowable		Measured	
			Min	Max	Motor A	Motor B
1	First peak current	A/mtr	1.05	1.70		
2	Free-running current (average)	A/mtr	0.02	0.18		
3	Post free-run current rise	A/mtr	0.20	1.70		
4	Time to initially cut power (1,2)	s	1.00	1.35		

- 1) It is acceptable for one motor to exceed the maximum allowable time to initially cut power.
- 2) Use the current channels to determine time.

Step	Procedure	Date & Initials	
		Tech.	QA
10.3.9	Disconnect the <i>SFF Power and Measurement Circuit</i> from the Lightband's DB-9 socket connector in Figure 10-3.		
10.3.10	<p>Measure resistance directly at the Lightband's DB-9 socket connector and complete Table 10-2. Contact PSC if a discrepancy is found.</p> <p>PSC recommends using a DMM. It will not cause damage to or operate the Lightband. If using a milliohm meter (four wire Kelvin probe system) ensure the test current is <0.01 A to prevent rotating the motors.</p> <p>See Figure 14-1 for the Set-For-Flight Motor Bracket Assembly switch state.</p> <p>Note: ensure the mating DB-9 pin connector is visibly clean to prevent contaminating the Lightband's socket connector.</p>		

Table 10-2: Set-For-Flight resistance measurements (values apply only at NTP)

Lightband State	Object Being Measured	Pin Connections	Resistance [Ω]	
			Allowable (1)	Measured
Set-For-Flight	Motor A	2 , 4	8.0 to 11.0	
	Motor B	6 , 8	8.0 to 11.0	
	Deploy Limit Switch A	1 , 2	< 0.3	
	Deploy Limit Switch B	5 , 6	< 0.3	
	Stow Limit Switch A	3 , 4	> 1E7	
	Stow Limit Switch B	7 , 8	> 1E7	
	Stow Limit Switch A	4 , 9	< 0.3	
	Stow Limit Switch B	8 , 9	< 0.3	
	Motor A Deploy Circuit	1 , 4	8.0 to 11.0	
	Motor B Deploy Circuit	5 , 8	8.0 to 11.0	

(1) Ensure the over limit (OL) indication on the resistance measurement device complies with the maximum tolerance. This is the case for the DMM referenced in Table 3-5.

11. Deploying the Lightband

This section will Deploy the Lightband. During the Deploy operation the Lightband's internal switches experience three collective switch states. Prior to Deploying, three test circuits will be operated to verify proper power and data acquisition. Emulating each switch state reduces the probability of an anomaly. In order, the states are

1. Stowed (full voltage and current draw for entire duration)
2. Intermediate (full voltage and current draw for entire duration)
3. Deployed (no voltage or current draw as this state emulates the Deploy switches cut power)

11.1 Deploy Test Circuit #1 (Stowed State)

Step	Procedure	Date & Initials	
		Tech.	QA
11.1.1	Oscilloscope shall record voltage and current per the following requirements: <ol style="list-style-type: none"> 1. Sample rate: $\geq 1,000$ Hz 2. Voltage resolution: ≤ 0.2 V 3. Current resolution: ≤ 0.02 A 		-----N/A-----
11.1.2	Set up the <i>Deploy Power and Measurement Circuit</i> portion of <i>Deploy Test Circuit #1</i> per Figure 11-1.		
11.1.3	May skip this step if no components/wiring were added since Set-For-Flight. Excessively long harnesses and/or thin wires have significant resistance which will reduce the voltage at the motors. Verify the resistance between the power source and Lightband connector is acceptable. This applies to the complete loop (power and return). PSC recommends the following method <ol style="list-style-type: none"> 1. Ensure power source output is off. 2. Set the timer relay function to '<i>D: One Shot</i>' and 5 s duration. 3. Set a DMM to measure resistance and connect it across the power source. 4. Jumper pin 1 to pin 4 on a DB-9 socket connector and connect to the <i>Deploy Power and Measurement Circuit</i>. 5. Activate the timer relay and read the DMM resistance measurement. It shall be $< 1.0 \Omega$. This verifies the Motor A portion of the circuit. 6. Remove the pin 1 to pin 4 jumper and connect pin 5 to pin 8. 7. Activate the timer relay and read the DMM resistance measurement. It shall be $< 1.0 \Omega$. This verifies the Motor B portion of the circuit. 8. Remove the jumper connector and DMM. 		
11.1.4	Set up the <i>Test Circuit: Stowed</i> portion of <i>Deploy Test Circuit #1</i> per Figure 11-1 and connect to the <i>Deploy Power and Measurement Circuit</i> .		

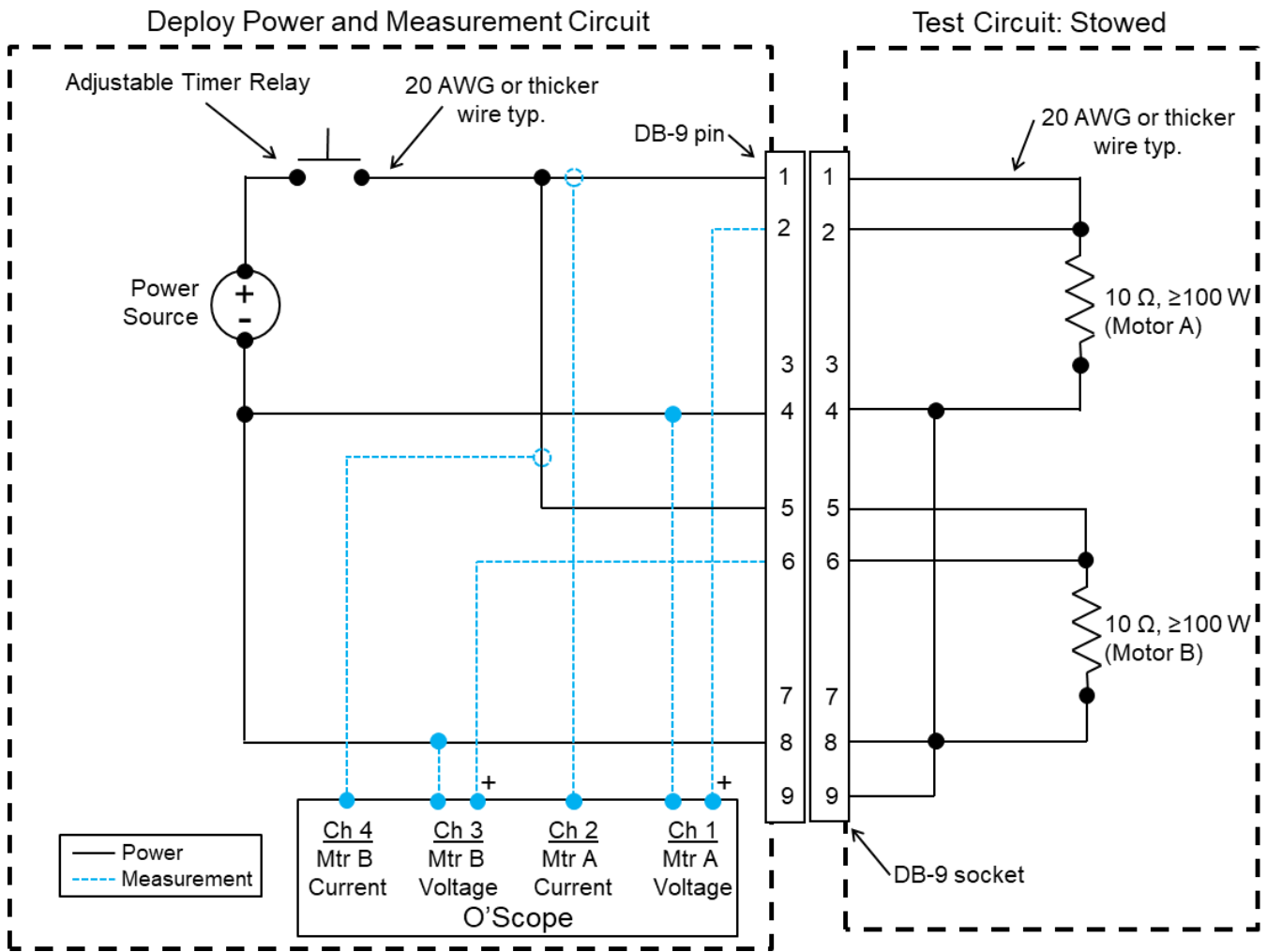

Figure 11-1: Deploy test circuit #1

Step	Procedure	Date & Initials	
		Tech.	QA
11.1.5	Set the power source voltage at 24 to 32 V_{DC} . When possible use the minimum voltage as this maximizes the Lightband's operating life and verifies worst-case torque margin.		
11.1.6	Set the current limit on the power source to 6.5 ± 0.1 A .		
11.1.7	Set the timer relay to apply power for 0.50 ± 0.05 s . If using the recommended timer, set its function to ' <i>D: One Shot</i> '.		
11.1.8	Adjust oscilloscope to properly capture all channels. Verify <ol style="list-style-type: none"> 1. Current probe scale matches oscilloscope on Ch. 2 & 4 (10A/V on oscilloscope & 100 mA/V on current probes) 2. Current probes are zeroed 3. Voltage scales on Ch. 1 & 3 (recommend 5 V/div) 4. Vertical positions on Ch. 1 & 3 (recommend zero at 1 div from bottom of screen) 5. Current scales on Ch. 2 & 4 (recommend 500 mA/div) 6. Vertical positions on Ch. 2 & 4 (recommend zero at 1 div from bottom of screen) 7. Horizontal time scale will capture entire duration (recommend 100 ms/div) 8. Horizontal trigger position (recommend 1 div from left of screen) 9. Vertical trigger level and channel (recommend Ch. 1 set to 2 V) 		
11.1.9	Perform the following to operate the test circuit. <ol style="list-style-type: none"> 1. Turn on the power source output. 2. Verify the oscilloscope trigger is active and ready to acquire data. 3. Activate the timer relay. 4. Verify the following occurred: <ol style="list-style-type: none"> 4.1. Voltage and current recorded per step 11.1.1 4.2. Measured voltage meets requirement in step 11.1.5 for Channels 1 & 3 4.3. Measured current values are approximately 1/10th of applied voltage for Channels 2 & 4 4.4. Timer relay applies power per step 11.1.7 4.5. Data saves and is readable on a computer 5. If positions or scales were altered to examine data, ensure they are returned to their original values. 6. Turn off the power source output. <p>If any parameters are not met, make the required changes and repeat this step. Upon completion of this step, the <i>Deploy Power and Measurement Circuit</i> shall not be changed.</p>		
11.1.10	Remove the <i>Test Circuit: Stowed</i> portion of <i>Deploy Test Circuit #1</i> in Figure 11-1.		----N/A----

11.2 Deploy Test Circuit #2 (Intermediate State)

Step	Procedure	Date & Initials	
		Tech.	QA
11.2.1	Set up the <i>Test Circuit: Intermediate</i> portion of <i>Deploy Test Circuit #2</i> per Figure 11-2 and connect to the <i>Deploy Power and Measurement Circuit</i> .		

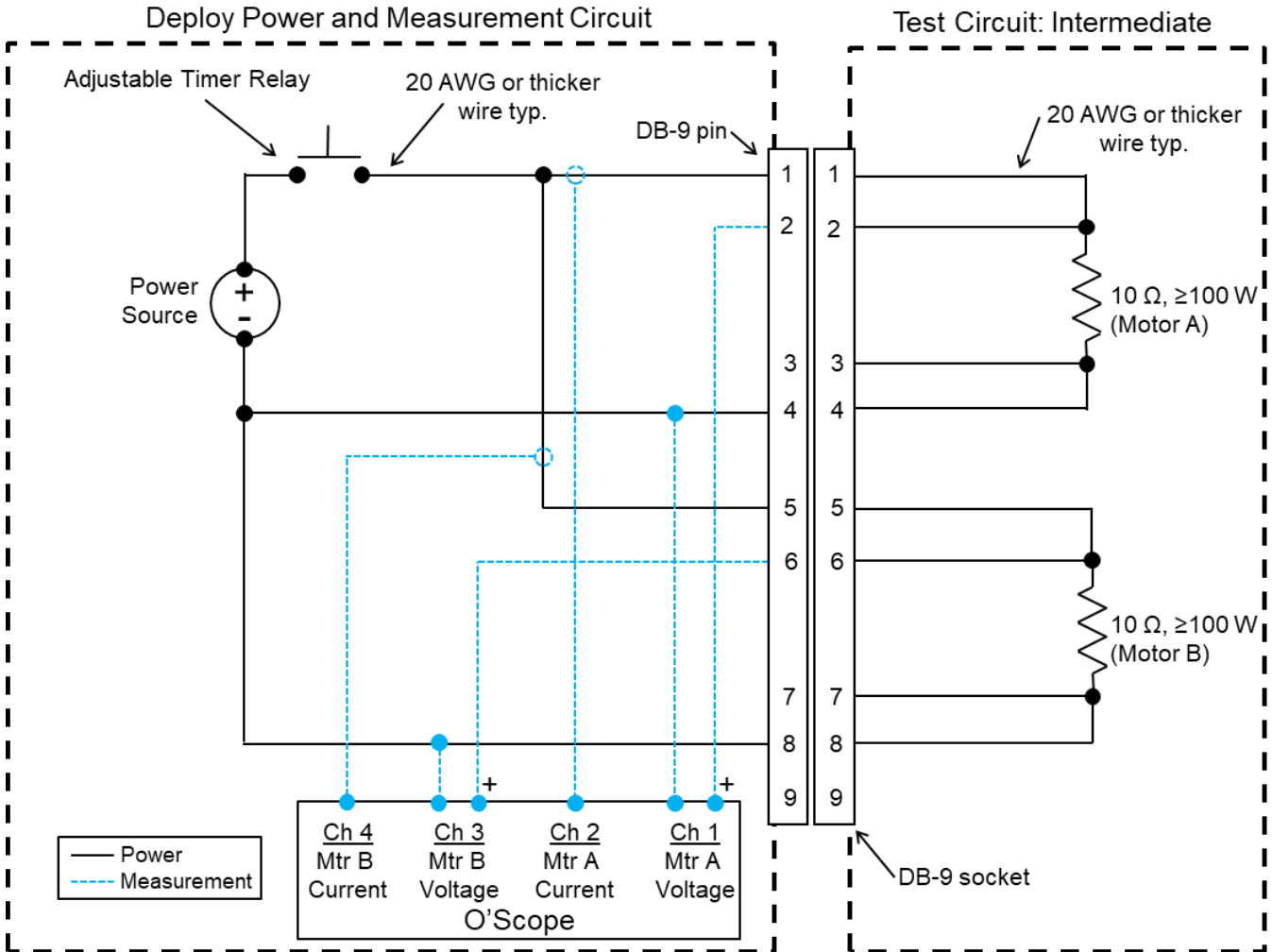

Figure 11-2: Deploy test circuit #2

Step	Procedure	Date & Initials	
		Tech.	QA
11.2.2	<p>Perform the following to operate the test circuit.</p> <ol style="list-style-type: none"> 1. Turn on the power source output. 2. Verify the oscilloscope trigger is active and ready to acquire data. 3. Activate the timer relay. 4. Verify the following occurred: <ol style="list-style-type: none"> 4.1. Voltage and current recorded per step 11.1.1 4.2. Measured voltage meets requirement in step 11.1.5 for Channels 1 & 3 4.3. Measured current values are approximately 1/10th of applied voltage for Channels 2 & 4 4.4. Timer relay applies power per step 11.1.7 4.5. Data saves and is readable on a computer 5. If positions or scales were altered to examine data, ensure they are returned to their original values. 6. Turn off the power source output. <p>If any parameters are not met, make the required changes and repeat this step. Any change to the <i>Deploy Power and Measurement Circuit</i> shall also require re-running <i>Deploy Test Circuit #1</i> per section 11.1.</p>		
11.2.3	Remove the <i>Test Circuit: Intermediate</i> portion of <i>Deploy Test Circuit #2</i> in Figure 11-2.		-----N/A-----

11.3 Deploy Test Circuit #3 (Deployed State)

Step	Procedure	Date & Initials	
		Tech.	QA
11.3.1	Set up the <i>Test Circuit: Deployed</i> portion of <i>Deploy Test Circuit #3</i> per Figure 11-3 and connect to the <i>Deploy Power and Measurement Circuit</i> .		

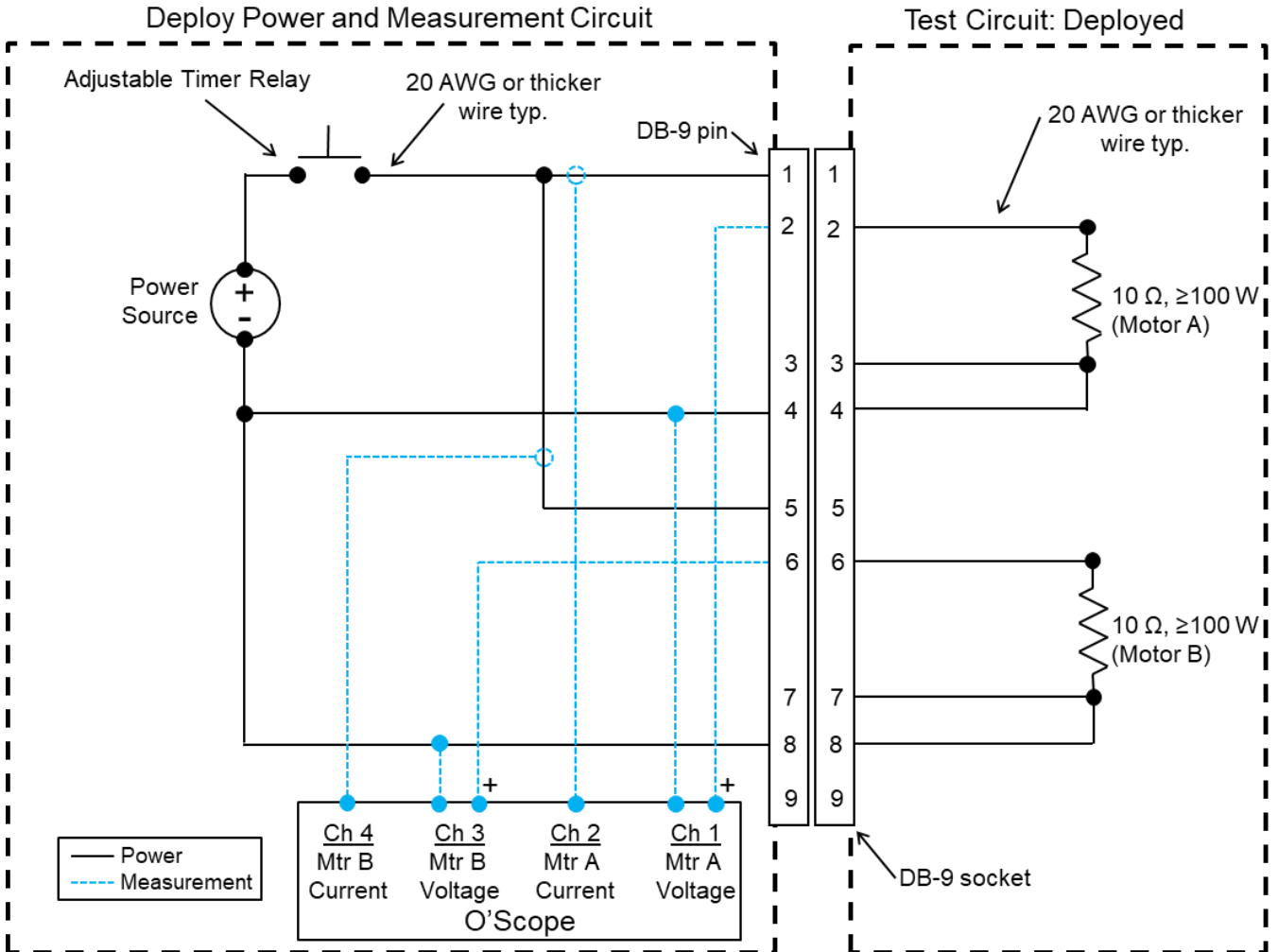

Figure 11-3: Deploy test circuit #3

Step	Procedure	Date & Initials	
		Tech.	QA
11.3.2	<p>Perform the following to operate the test circuit.</p> <ol style="list-style-type: none"> 1. Designate a person to watch the power source output display. 2. Turn on the power source output. 3. Verify the oscilloscope trigger is active and ready to acquire data. 4. Activate the timer relay. 5. Verify the following occurred: <ol style="list-style-type: none"> 5.1. All four measurement channels (voltage and current) remained at zero. The oscilloscope should not trigger. 5.2. The power source's current indicator remained at zero. This ensures even a small voltage or current, below the oscilloscope's trigger level, did not pass through. 6. If positions or scales were altered to examine data, ensure they are returned to their original values. 7. Turn off the power source output. <p>If any parameters are not met, make the required changes and repeat this step. Any change to the <i>Deploy Power and Measurement Circuit</i> shall also require re-running <i>Deploy Test Circuit #1</i> per section 11.1 and <i>Deploy Test Circuit #2</i> per section 11.2.</p>		
11.3.3	Remove the <i>Test Circuit: Deployed</i> portion of <i>Deploy Test Circuit #3</i> in Figure 11-3.		-----N/A-----

11.4 Deploy

Step	Procedure	Date & Initials	
		Tech.	QA
11.4.1	<p>The Upper Ring shall be constrained during Deployment. If Separating (allowing the Separation Springs to fully extend) skip to step 11.4.2. If Separating is not required, a force shall be applied to restrain the Upper Ring. Apply a compressive force on the Upper Ring per the calculations below.</p> <p>Separation Spring quantity = _____</p> <p>Minimum Compressive Force = ____ Springs x 20 lb = _____ lb</p> <p>Maximum Compressive Force = ____ Springs x 30 lb = _____ lb</p> <p>Offload any object heavier than the maximum compression force.</p> <p>Once this step is complete, skip to step 11.4.3.</p>		
11.4.2	<p>If separating (allowing the Separation Springs to fully extend) it is required to constrain the Upper Ring after the Separation Springs reach end of stroke. <i>2000843 Deploy Upper Ring Stops</i> or similar shall be used. See Section 15. If using Deploy Upper Ring Stops, follow PSC procedure <i>3000272</i> for installation instructions.</p> <p>Another option is to allow the Lower Ring to drop onto soft high-damping foam (ensure re-contact with Upper Ring is not possible). The foam shall be covered to prevent contaminating the Lightband. To prevent Lightband damage, drop distance and energy damping shall be considered.</p>		

Step	Procedure	Date & Initials	
		Tech.	QA
11.4.3	Verify the DB-9 pin connector of the <i>Deploy Power and Measurement Circuit</i> in Figure 11-4 is visibly clean. Any debris could detrimentally contaminate the Lightband's mating socket connector.		
11.4.4	Connect the Lightband to the <i>Deploy Power and Measurement Circuit</i> per Figure 11-4. Do not apply power to the Lightband.		

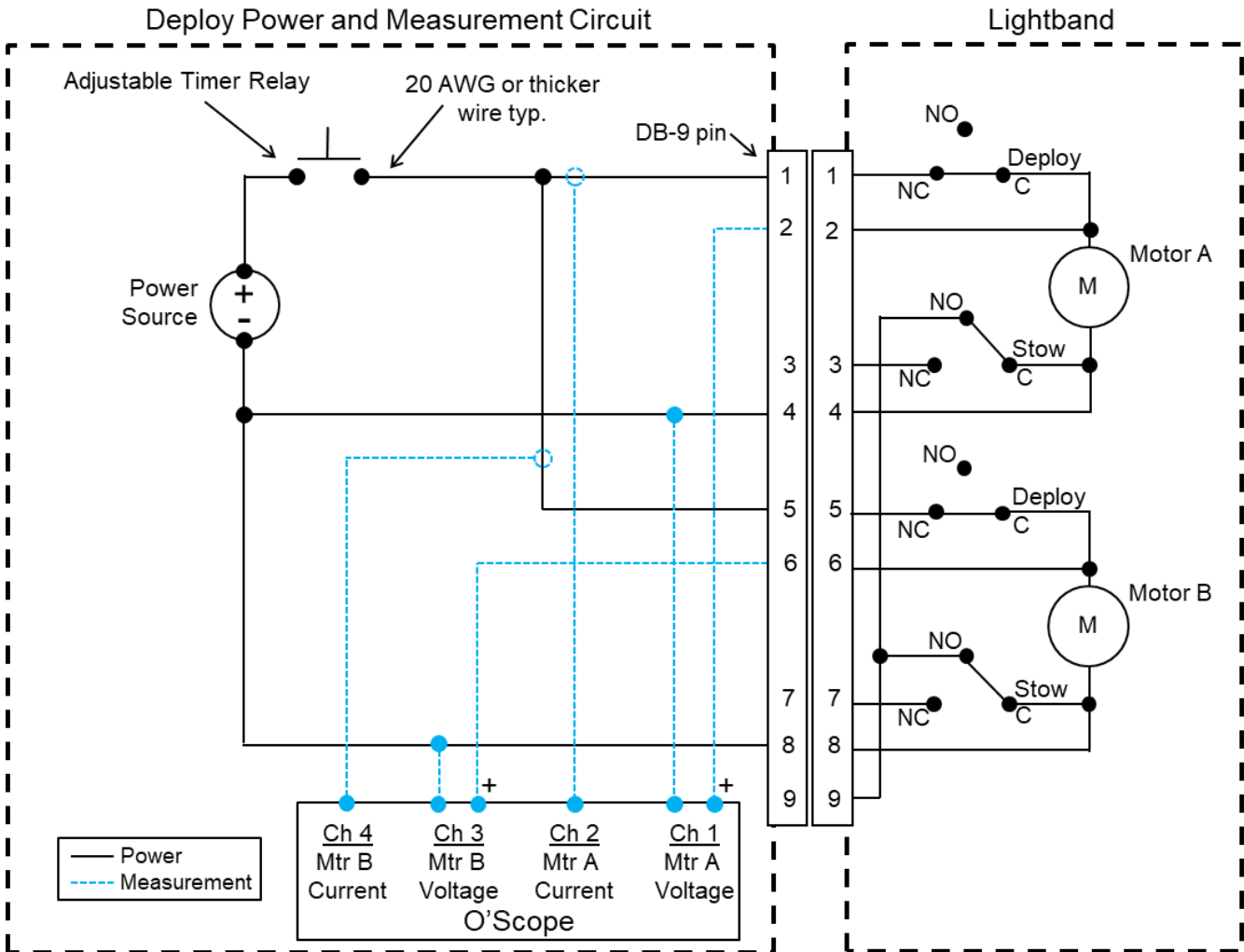

Figure 11-4: Deploy circuit

Step	Procedure	Date & Initials	
		Tech.	QA
11.4.5	PSC recommends recording video and audio of the Deploy operation. This is not required but has proven very helpful in determining root cause in the unexpected event of an anomaly.		-----N/A-----
11.4.6	<p>To Deploy the Lightband:</p> <ol style="list-style-type: none"> 1. See Figure 11-5 and Table 11-1 for the anticipated current draw and power duration. 2. If a force was applied per step 11.4.1 the Upper Ring will not move. This force will be removed at a later step, allowing the Separation Springs to extend. 3. Designate a person to watch the power source output display. 4. Turn on the power source output. 5. Verify the oscilloscope trigger is active and ready to acquire data. 6. Activate the timer relay. This will send power to the motors and Deploy the Lightband. The Lightband should Deploy in ≤ 0.1 s and the Deploy limit switches on the Motor Bracket Assembly will automatically cut power to the motors. <p>Manually cut power if the current limit is reached or the timer relay runs longer than specified. Then contact PSC per section 5. A visual inspection of the Lightband may be performed, but do not change configuration.</p>		
11.4.7	Take a picture of the oscilloscope screen in case data inadvertently gets erased.		
11.4.8	Turn off the power source output.		
11.4.9	Save the voltage and current profiles for both motors and verify the data is readable.		
11.4.10	<p>Figure 11-5 shows example Deploy voltage and current profiles. Complete Table 11-1 to verify all parameters are within tolerance. Single data point exceedances are acceptable. Also, a slow sample rate may alias data. Do not filter data. Contact PSC immediately if a discrepancy is found.</p> <p>Remember to account for non-zero offsets in the voltage or current measurements.</p>		

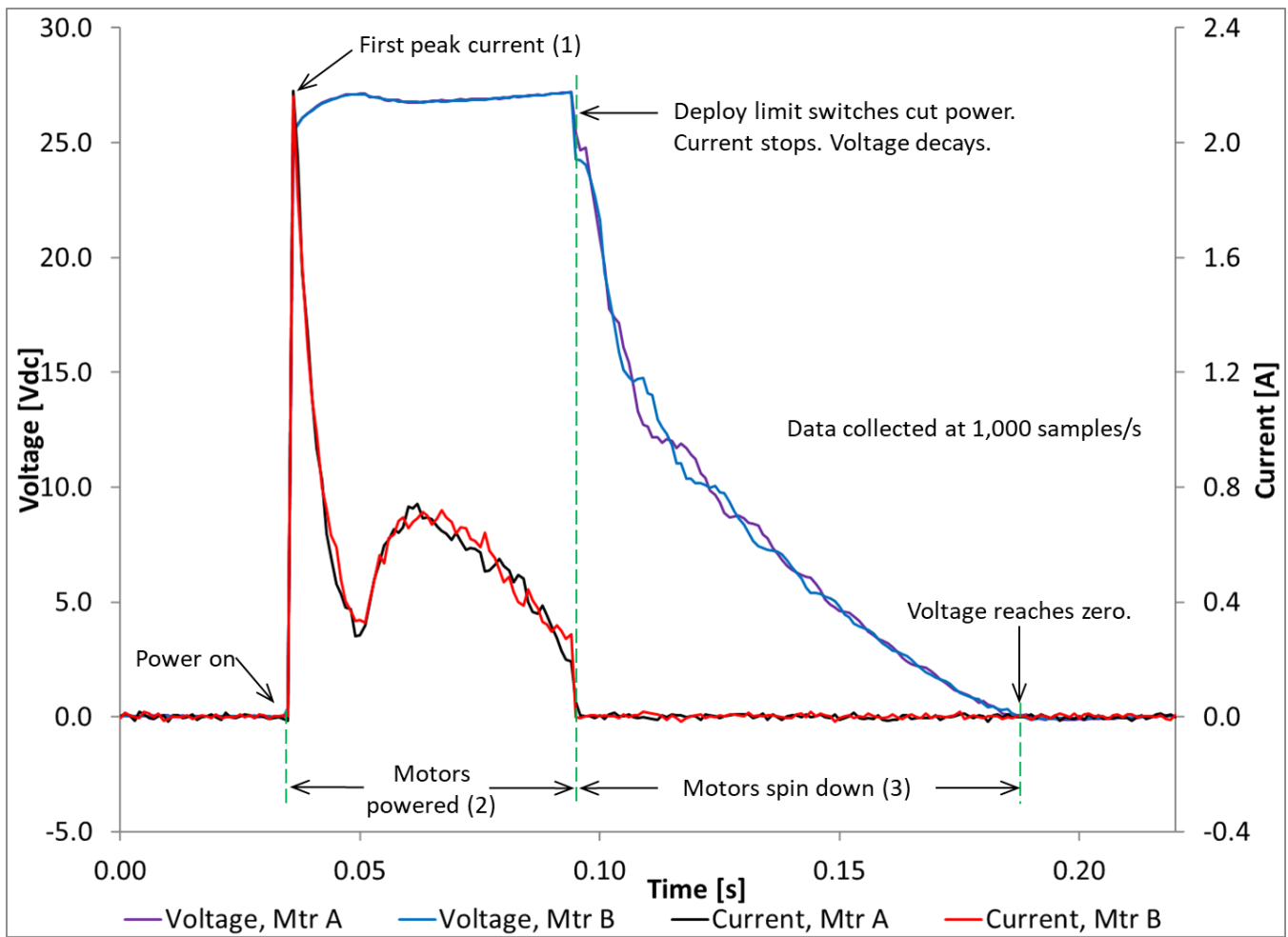

Figure 11-5: Example Deploy voltage and current profiles at NTP

Table 11-1: Deploy electrical verification (values apply only at NTP)

Deploy Electrical Parameters						
Item	Description	Units	Allowable		Measured	
			Min	Max	Motor A	Motor B
1	First peak current	A/mtr	1.7	3.4		
2	Motor powered duration (1,2)	s	0.04	0.10		
3	Motor spin down duration	s	0.03	0.40		

- 1) Use the current channels to determine duration.
- 2) This is the time to initially cut power. It is acceptable for one or both Deploy switch(es) to temporarily re-activate and permit power to the motor(s). This re-activation duration shall be <0.05 s.

Step	Procedure	Date & Initials	
		Tech.	QA
11.4.11	Disconnect the <i>Deploy Power and Measurement Circuit</i> from the Lightband's DB-9 socket connector.		
11.4.12	<p>Measure resistance directly at the Lightband's DB-9 socket connector and complete Table 11-2. Contact PSC if a discrepancy is found.</p> <p>PSC recommends using a DMM. It will not cause damage to or operate the Lightband. If using a milliohm meter (four wire Kelvin probe system) ensure the test current is <0.01 A to prevent rotating the motors.</p> <p>See Figure 14-1 for the Deployed Motor Bracket Assembly switch state.</p> <p>Note: ensure the mating DB-9 pin connector is visibly clean to prevent contaminating the Lightband's socket connector.</p>		

Table 11-2: Deploy resistance measurements (values apply only at NTP)

Lightband State	Object Being Measured	Pin Connections	Resistance [Ω]	
			Allowable (1)	Measured
Deployed	Motor A	2 , 4	8.0 to 11.0	
	Motor B	6 , 8	8.0 to 11.0	
	Deploy Limit Switch A	1 , 2	> 1E7	
	Deploy Limit Switch B	5 , 6	> 1E7	
	Stow Limit Switch A	3 , 4	< 0.3	
	Stow Limit Switch B	7 , 8	< 0.3	

(1) Ensure the over limit (OL) indication on the resistance measurement device complies with the maximum tolerance. This is the case for the DMM referenced in Table 3-5.

Step	Procedure	Date & Initials	
		Tech.	QA
11.4.13	<p>This step shall be skipped if the Lightband was allowed to Separate (Separation Springs fully elongate).</p> <p>Slowly remove the weight/force on the Upper Ring, allowing the Separation Springs to elongate. Verify the Upper and Lower Rings physically separate.</p> <p>If using a crane, continuously monitor an in-line load cell to ensure the Upper Ring properly releases.</p> <p>If <i>Deploy Upper Ring Stops</i> were used, remove them per PSC procedure 3000272.</p>		

12. Removing the Lightband from Adjoining Structures

Step	Procedure	Date & Initials	
		Tech.	QA
12.1.1	<p>Removing the Lower Ring of an MLB 15.000-24 only. All other sizes shall skip this step. Also skip this step if using reduced head fasteners per section 15.</p> <p>Remove the Lower Ring by reversing step 7.1.9. If adjoining structure holes are threaded, back out the fasteners slowly to prevent jamming the heads against the Leaf Pins. Once all fasteners are loose, hold the washer against the Lower Ring and pull the screw out. Push the Leaf Pins to either side if they rub the screw head. Then remove the washers. See Figure 12-1 & Figure 12-2. Upon completion skip to step 12.1.3.</p>		
12.1.2	<p>Removing the Lower Ring on all Lightbands other than an MLB 15.000-24 or if using reduced head fasteners per section 7.</p> <p>Remove the Lower Ring by reversing step 7.1.8.</p> <p>It is often helpful to hold the washer against the Lower Ring while pulling the screw out separately. See Figure 12-1 & Figure 12-2.</p>		
12.1.3	Remove the Upper Ring from the adjoining structure by reversing step 7.1.11.		



Figure 12-1: Removing a SHC screw from the Lower Ring, outer view



Figure 12-2: Removing a SHC screw from the Lower Ring, inner view

13. Horizontal Integration (Optional)

Horizontal integration may be necessary due to space vehicle (SV) and/or launch vehicle (LV) limitations. This section describes the steps and precautions necessary to ensure proper Stowing of the Lightband.

Step	Procedure	Date & Initials	
		Tech.	QA
13.1.1	Is an isolation system attached to the Lower Ring? If so, it may be easier to Stow the Lightband with Transition Rings, remove the Transition Rings, and then bolt the already mated Lightband to the LV and SV. Contact PSC for details.	-----N/A-----	-----N/A-----
13.1.2	The Lower Ring, mounted to the LV, shall be perpendicular to level within $\pm 0.2^\circ$. See Figure 13-1.		
13.1.3	Micro-adjustment of the SV height, pitch and roll is essential. This can be accomplished with a hydro-set, Vernier screws, turnbuckles, etc.		
13.1.4	The structure supporting the SV (crane, tilt-cart, etc.) shall have sufficient compliance to allow for SV movement when Stowing. The vertical stiffness shall be less than 2,000 lb/in. Consider and verify compliance in all 6 degrees of freedom (DOF). For instance, will the crane stretch, the tilt cart compress or even be lifted up? Can the SV pitch, roll or yaw as necessary?		
13.1.5	A load cell shall be installed in-line with the SV support structure. See Figure 13-1 and Figure 13-3.		
13.1.6	Move the SV close to the LV until the tips of the Separation Springs are close to the bottom edge of the Upper Ring (<0.5 inch) but not yet overlapping. Align the Upper Ring to the Lower Ring in translation and rotation. See step 8.1.11 for alignment features. Ensure the Separation Springs will not be inhibited from engaging their corresponding holes in the Upper Ring flange. It is essential to align all 6 SV DOF prior to actually compressing the Lightband. See Figure 13-2.		
13.1.7	Verify no part of the Lower Ring is contacting the Upper Ring and then record the SV load cell reading: _____		
13.1.8	Move the SV closer to the LV until the conical tips of the Separation Springs are <0.10 in from the Upper Ring flange. All Separation Spring tips shall be centered in their corresponding Upper Ring flange holes. The Lower and Upper Rings shall be parallel within 0.02 inch. Adjust the SV alignment as necessary. The load cell shall remain within 10 lb of the step 13.1.7 reading.		
13.1.9	Move the SV closer to the LV until the conical tips of all Separation Springs are engaged and centered in the Upper Ring flange holes. The Lower and Upper Rings shall be parallel within 0.01 inch. Adjust the SV alignment as necessary. The load cell shall remain within 10 lb of the step 13.1.7 reading.		
13.1.10	Slowly compress the Lightband. See Section 18 if using LCTs. Continually monitor the load cell. It shall remain within 10 lb of the step 13.1.7 reading. When fully compressed, the distance between Lightband flanges shall conform to Step 8.1.14. Also verify that the flange distance at the top, bottom, left and right of the Lightband are within 0.005 inch of one another. See Figure 13-3. An improperly aligned SV may translate (up, down, left or right) or rotate (pitch, roll or yaw) during the Stow process, requiring additional power that the Lightband motors cannot generate. Proper alignment is essential.		
13.1.11	Record final load cell reading: _____		
13.1.12	Return to section 9 to Stow the Lightband.	-----N/A-----	-----N/A-----

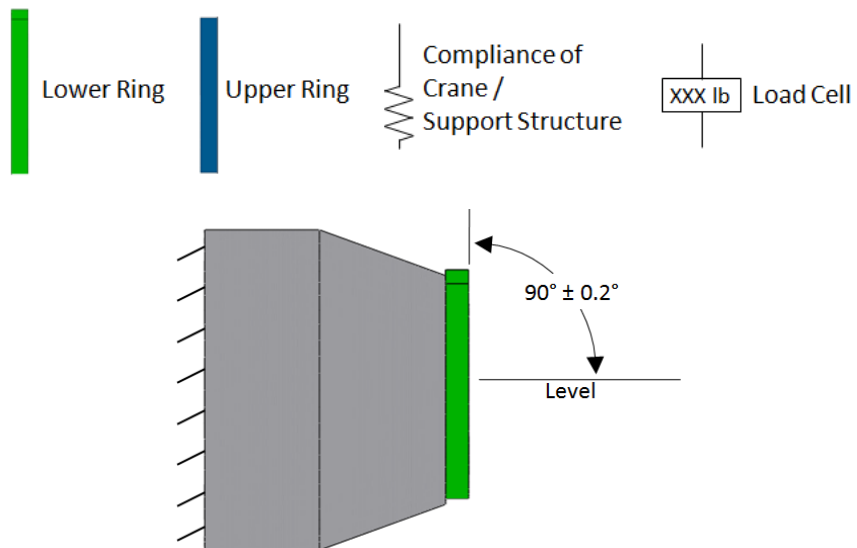

Figure 13-1: Verify Lower Ring is leveled prior to mating SV.

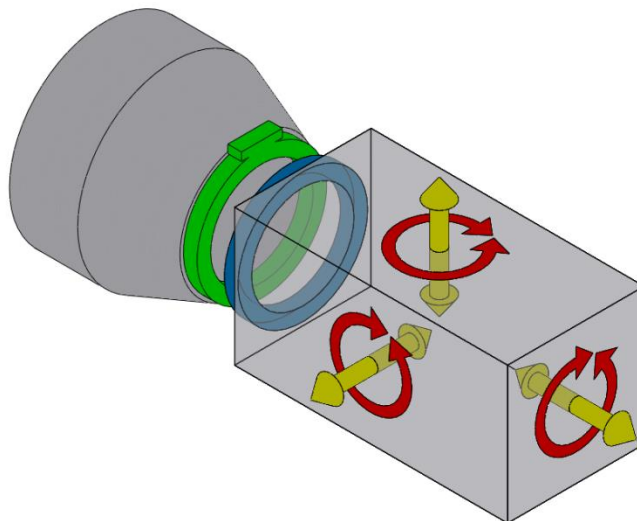

Figure 13-2: Be cognizant of translational and rotational alignment and compliance.

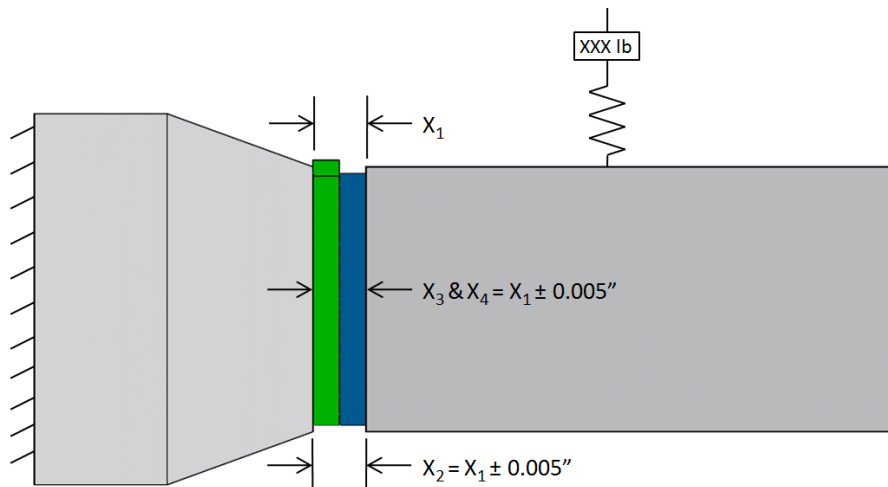

Figure 13-3: Verify parallelism of compressed Lightband.

14. Lightband Electrical Schematics

Figure 14-1 shows the switch states during and after each Lightband operation. Note that Stowed and Set-For-Flight have the same final switch states. During operation, the switches temporarily change to the Intermediate State shown below. This occurs when the Sliding Tube is not contacting either the Stow or Deploy limit switches.

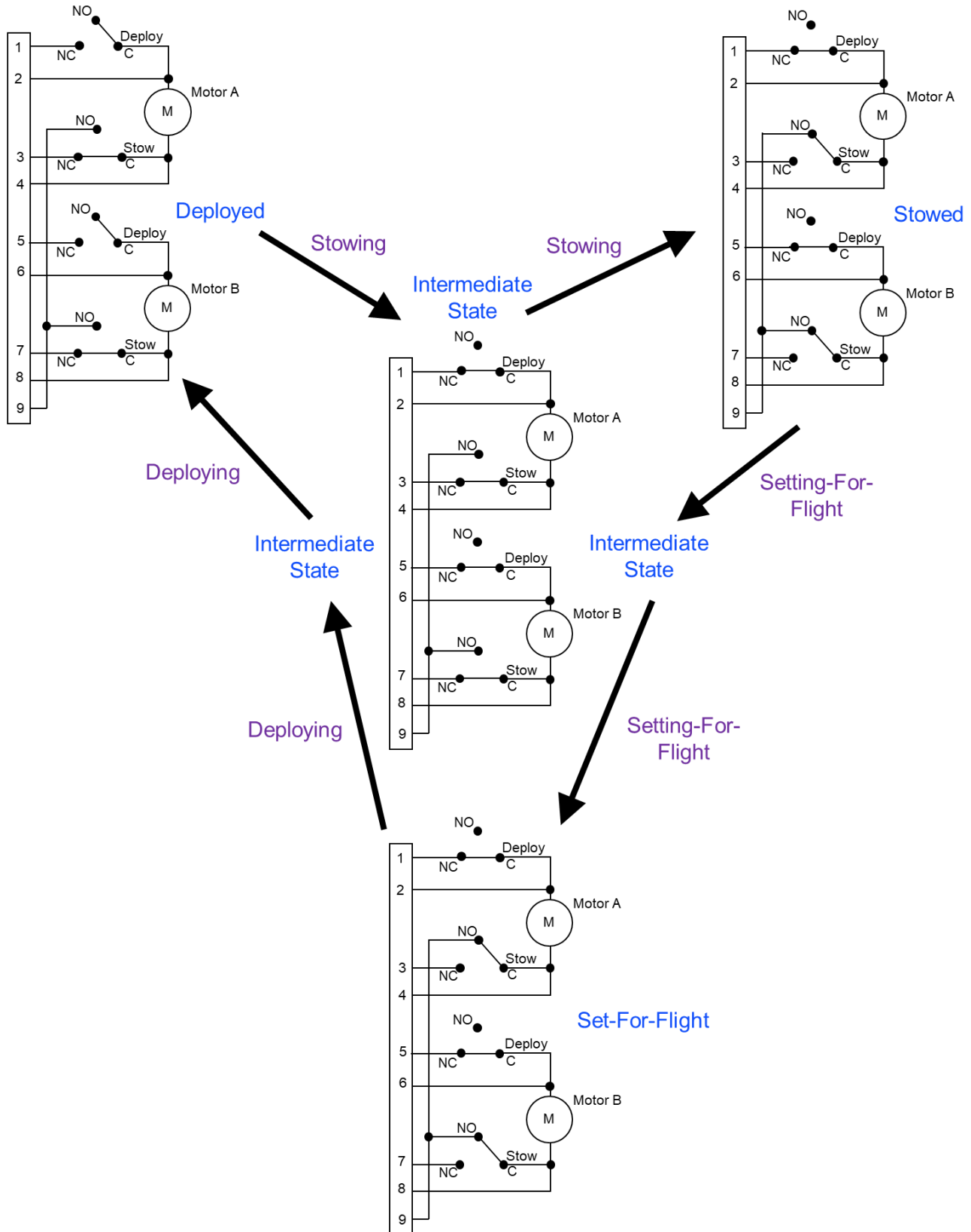



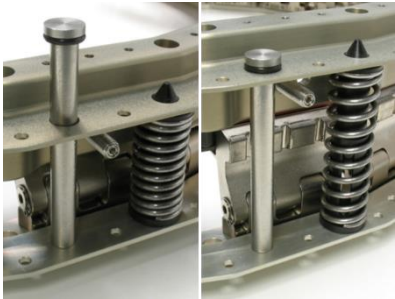



Figure 14-1: Lightband switch states

15. Recommended Support Equipment

The following is a list of equipment PSC has developed over years of Lightband operation and training. This equipment is not required for proper Lightband operation but is very useful. PSC does not supply any of the items listed below. See PSC's website to download drawings of these parts.

Table 15-1: Support equipment

Tip	Steps	Best Practice / Lesson Learned	Image
1	7.1.2 7.1.9	On the MLB 15.000-24 PSC uses 0.25-28 SHC screws with the head diameter reduced. This eliminates the interference fit described in step 7.1.9. Part: <i>4000845 Reduced Head SHC Screw</i>	
2	7.1.3 7.1.4 7.1.5 8.1.1	PSC uses custom aluminum transition rings as adjoining structures for all Lightband operations and testing. They provide the necessary stiffness to operate the Lightband and ease attachment to other structures. They also facilitate Lightband circularity requirements. Part: <i>2000741 Transition Ring</i>	
3	8.1.14	Use of a go/no-go gauge simplifies verification of the Lightband's pre-Stow distance. Part: <i>2002486 MLB Go No Go Stow Gauge</i>	
4	11.4.2	PSC occasionally uses custom guide rods (Deploy Upper Ring Stops) to restrain the Upper Ring during separation. They stop the Upper Ring at full Separation Spring extension. This is helpful if immediate separation is desired after Deployment. Part: <i>2000843 Deploy Upper Ring Stop</i>	
5	7.1.5 7.1.8 7.1.9 7.1.11	PSC ensures circularity of Lower and Upper Rings by aligning to adjoining structures with custom flat head screws. They are 82° flat head screws with the head diameter reduced to fit between Leaves. Part: <i>2002753 FLH Alignment Screw</i>	

16. Setup Pictures

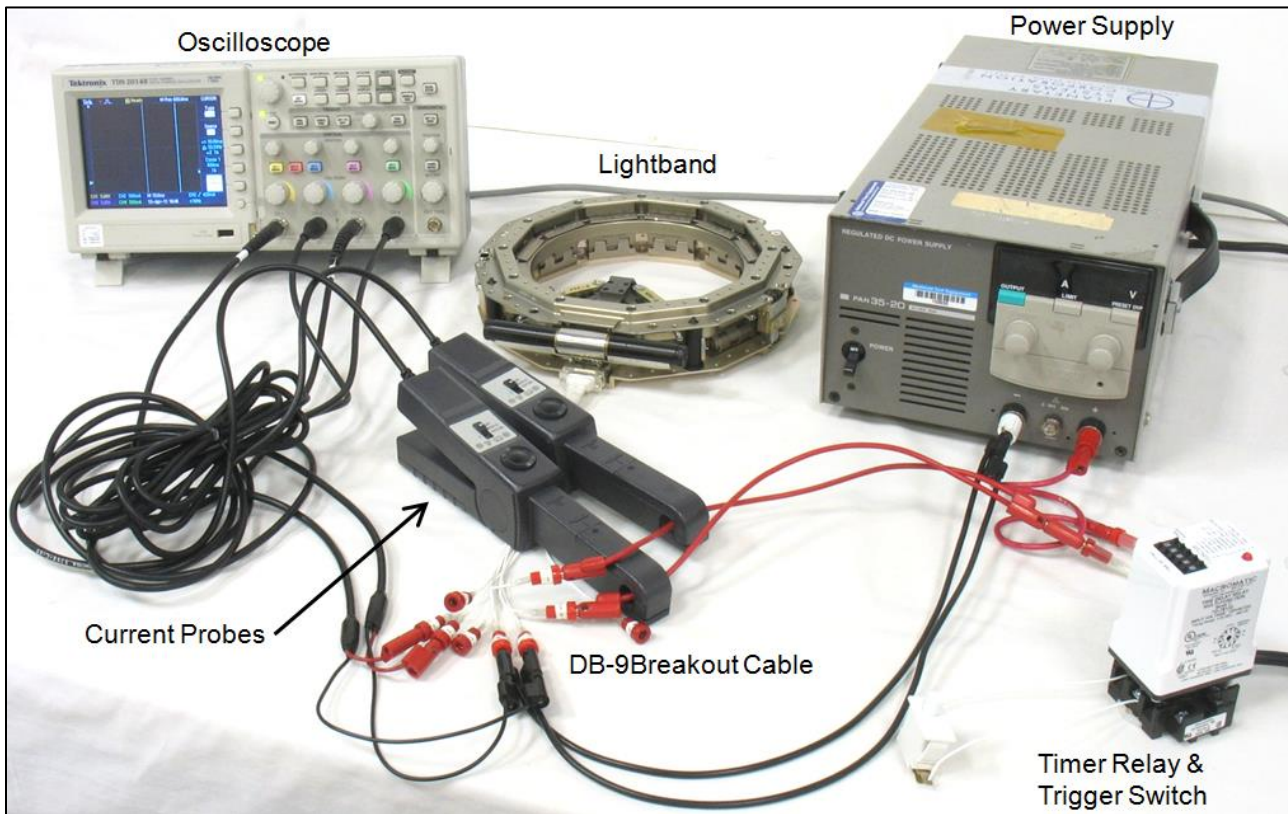

Figure 16-1: Example of equipment used to operate Lightband and record voltage and current.



Figure 16-2: DMM and DB-9 breakout cable used to measure Motor Bracket Assembly resistance.

17. Caution - Unintended Electrical Paths

By modifying the Power and Measurement Circuits, several customers have caused anomalies while operating the Lightband. They created unintended electrical paths that bypassed limit switches and/or shorted motors. This in-turn permanently damaged, or unexpectedly deployed, the Lightband. The customer shall be extremely confident in any changes to the Power and Measurement Circuits prior to operating a Lightband. The most common causes for these unintended electrical paths include, but are not limited to:

1. During the Stow and Deploy operations, the Lightband's switches will change state to a temporary intermediate position as shown in Figure 14-1.
2. The Lightband motors share a common pin 9 that can connect them under certain instances.
3. Most oscilloscopes have a common ground. Therefore, all 'negative' probes are connected to each other. Consider this when connecting the voltage probes. Reminder PSC strongly recommends using an oscilloscope with isolated channels.
4. The user changed the voltage probe connection pins during Set-For-Flight from those recommended by PSC and inadvertently bypassed the limit switches, Deploying the Lightband.
5. The user connected the oscilloscope ground to earth ground and inadvertently bypassed the limit switches. The Lightband thus Deployed instead of the expected Set-For-Flight.
6. The user chose to measure current not by current probes but by measuring voltage drop across a resistor and inadvertently bypassed a limit switch.

The figure below shows a Set-For-Flight operation performed using an oscilloscope with common probe grounds. Current can bypass the first open switch and run through the voltage probes to the second Stow switch. The resulting voltage and current profiles will make it appear as if both switches are synced even though they may not actually be. Although this is not detrimental to the Lightband, it is an example of unintended electrical paths.

In the circuit below the Stow A limit switch changes to NC, but power can still flow from pin 4 back to pin 8 and through the Stow B limit switch to pin 9 until the Stow B switch changes to NC.

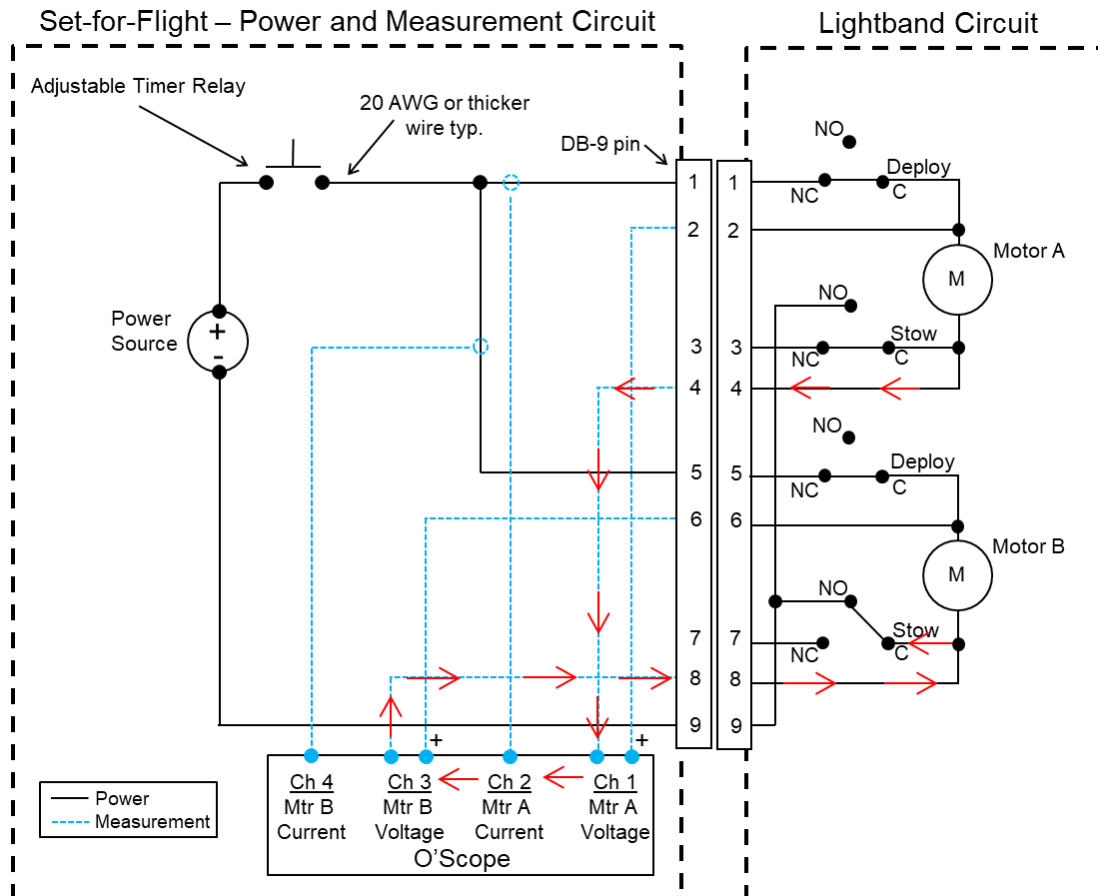

18. LCT Procedure

PSC part 4000637 *Lightband Compression Tool (LCT)* can be used to compress the Lightband prior to Stowing. They are ideal if the satellite weighs less than the total Separation Spring compressive force or during horizontal integration.

Note, an LCT consists of a single assembly. A pair of LCTs, one on the Lower Ring and one on the Upper Ring, are required at each location.

18.1 Equipment

Figure 18-1 shows the individual equipment necessary to operate LCTs and also the LCTs installed on the Lightband. See Table 3-6 for a detailed equipment list.

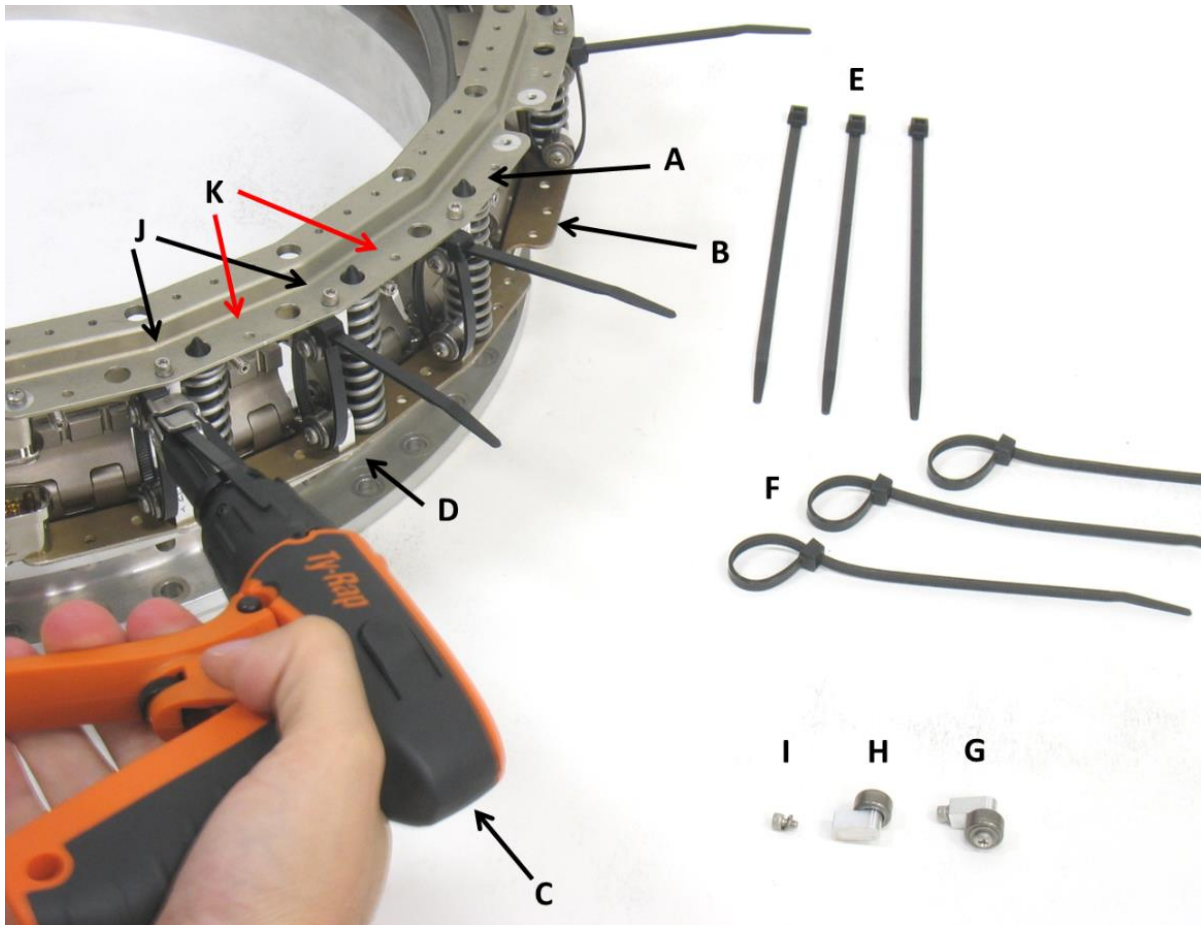

Figure 18-1: LCT Equipment

- A: Lightband Upper Ring flange
- B: Lightband Lower Ring flange
- C: Ty-Rap ERG 50 cable tie tool
- D: LCT Pair with cable tie installed
- E: MS 3367-1-0, 7-inch nylon cable ties (before installation)
- F: Cable ties (removed after Stowing)
- G: Single LCT assembly
- H: Primary portion of LCT
- I: Attachment screw and washer of LCT
- J: Correct LCT attachment points
- K: Incorrect LCT attachment points

18.2 LCT Installation

Step	Procedure	Date & Initials	
		Tech.	QA
18.2.1	<p>Calculate the quantity of LCT pairs required using PSC document 2000785 <i>MkII MLB User Manual</i>.</p> <p>Required LCT qty. [pair] = _____</p> <p>Actual LCT qty. [pair] = _____</p>		
18.2.2	<p>Attach one half of the LCT pairs to the Lightband Upper Ring flange. Only use the outboard corner holes of the flange shown in Figure 18-1 and locate each LCT as close to a Separation Spring as possible. Restrain the LCT with a 1/4 inch open-end wrench while torquing the screw with a 3/32 inch hex key as shown in Figure 18-2.</p> <p>Torque screws 10 to 12 in·lb total. Maximum running torque is 8 in·lb.</p> <p>Note: An LCT placed between adjacent Separation Springs must be rotated outward to ensure the LCT's bearing clears both Springs. Since the LCT will now protrude radially outward from the Lightband's default stayout diameter, ensure this protrusion is acceptable for both the payload and LV.</p>		
18.2.3	<p>Attach the other half of the LCT pairs to the Lightband Lower Ring flange directly aft of every Upper Ring LCT. Restrain the LCT with a 1/4 inch open-end wrench while torquing the screw with a 3/32 inch hex key as shown in Figure 18-2.</p> <p>Torque screws 10 to 12 in·lb total. Maximum running torque is 8 in·lb.</p> <p>Ensure each LCT pair is visually aligned as shown in Figure 18-3.</p>		

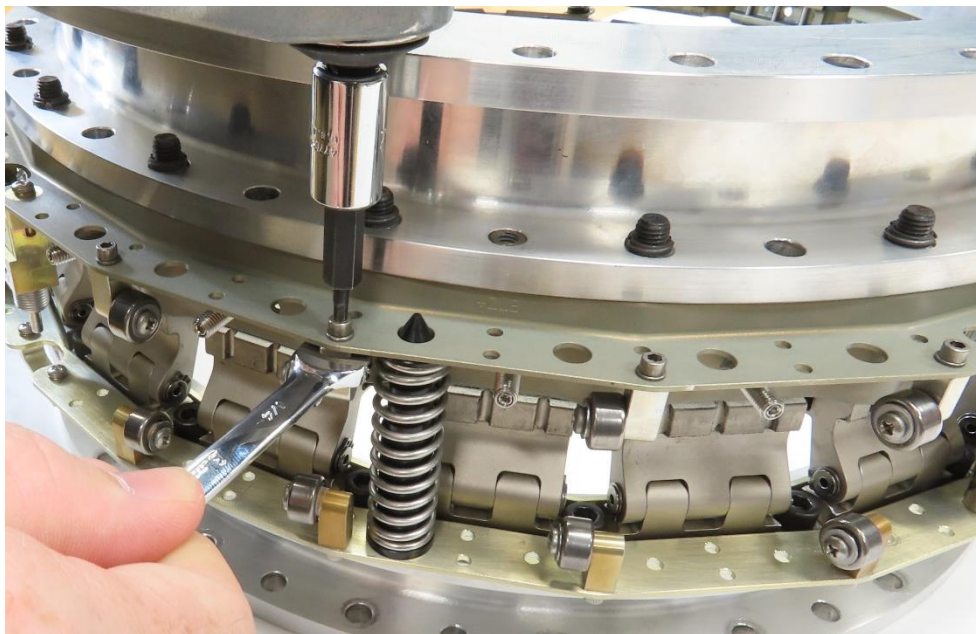

Figure 18-2: Attaching an LCT to the Lightband



Figure 18-3: Visually aligned LCT pair

18.3 Mating the Lightband

Step	Procedure	Date & Initials	
		Tech.	QA
18.3.1	Upper and Lower Rings shall be aligned per Step 8.1.11.		
18.3.2	Prepare cable tie tool 1. Disable cut-off feature (if present). 2. Ensure force setting does not exceed cable tie break strength. If using referenced tool, set to '8'.		
18.3.3	Place one cable tie around each LCT pair and pull until just taut. Do not compress the Separation Springs.		
18.3.4	Measure the distance between Upper and Lower Ring flanges (A and B in Figure 18-1) next to each LCT and record in Table 18-1. For reference the nominal uncompressed distance is 2.13 inch for the dimension shown in Figure 8-7. Lightly tighten each cable tie until the flange distance measures 2.00 to 2.05 inch at every LCT (1). Note: Failure to evenly compress the Lightband increases probability of breaking cable ties.		

1) If using a combination of weight and LCTs to compress the Lightband, the initial flange distance will be less than stated above. Record the minimum initial reading and adjust all LCTs until they are within 0.05 inch.

Step	Procedure	Date & Initials	
		Tech.	QA
18.3.5	To compress the Lightband tighten the cable ties in maximum increments of 0.05 inch. Work around the Lightband and record all measurements in Table 18-1 after each round of adjustments. The flange distance at all LCTs shall agree within 0.05 inch prior to compressing further. If a cable tie is over-tightened or breaks, remove and replace the cable tie. Repeat this iterative process until the flange distance at every LCT complies with the pre-Stow distance in Figure 8-7.		
18.3.6	Proceed to section 9 to Stow the Lightband.	-----N/A-----	-----N/A-----

18.4 Flange Gap Measurements

Table 18-1: Flange Measurements

Meas. #	Distance Between Upper and Lower Ring Flanges [in]											
	LCT 1	LCT 2	LCT 3	LCT 4	LCT 5	LCT 6	LCT 7	LCT 8	LCT 9	LCT 10	LCT 11	LCT 12
1												
2												
3												
4												
5												
6												
7												
8												
9												
10												
11												
12												
13												
14												
15												
16												

18.5 LCT Removal

Step	Procedure	Date & Initials	
		Tech.	QA
18.5.1	Remove all cable ties by either sliding them off the LCT bearings or cutting them. Take inventory to ensure all were removed. Also inspect the Lightband near each LCT to ensure no small cable tie pieces broke off.		
18.5.2	Optional Step: If desired, the LCTs may be removed from the Lightband. To do so hold the LCT with a 1/4 inch wrench and remove the screw with a 3/32 inch hex key. See Figure 18-2. Take care not to lose the small washer. Take inventory and ensure all components were removed and accounted for.		

In unique circumstances the customer may be unable to Stow the Lightband as intended and therefore need to reverse section 18.4 to un-Mate and Separate the Lightband. The cable ties must be incrementally extended to prevent overstressing the Lightband's thin Lower Ring and Upper Ring flanges. The reversal process is as follows

1. Slide a single cable tie off an LCT pair and measure its effective loop length.
2. Take a new cable tie and create a slightly longer loop such that the Lightband flange distance will increase ~0.05 inch. Assuming the cable ties are the same length, the exposed length will decrease ~0.1 inch. See Figure 18-4.
3. Slide this new cable tie over the LCT pair.
4. Work all the way around the Lightband, repeating steps 1 through 3 for each LCT pair.
5. Repeat steps 1 through 4 until the Separation Springs are fully extended.

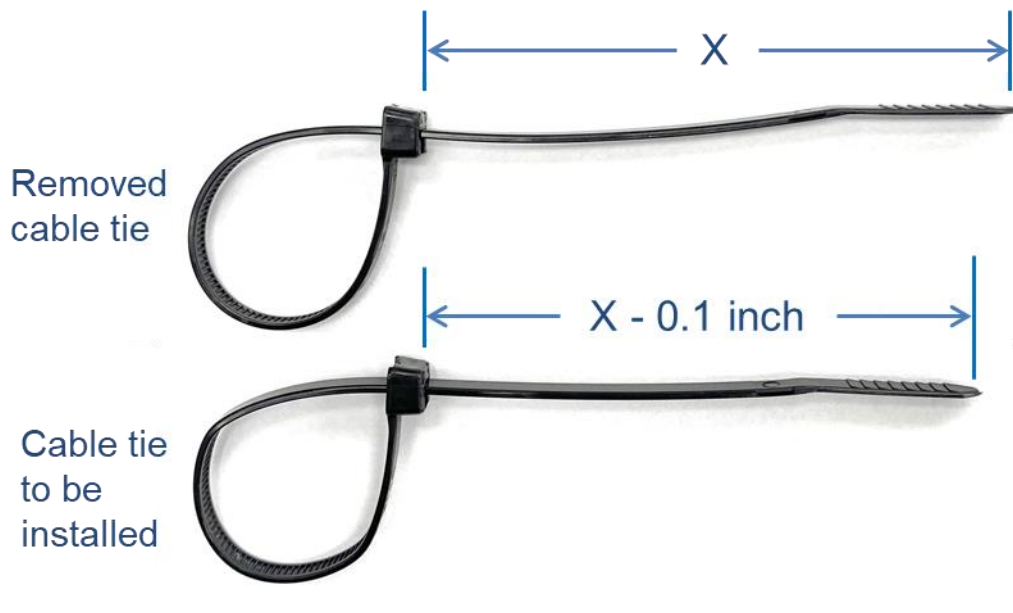

Figure 18-4: LCT reversal length